

HSF

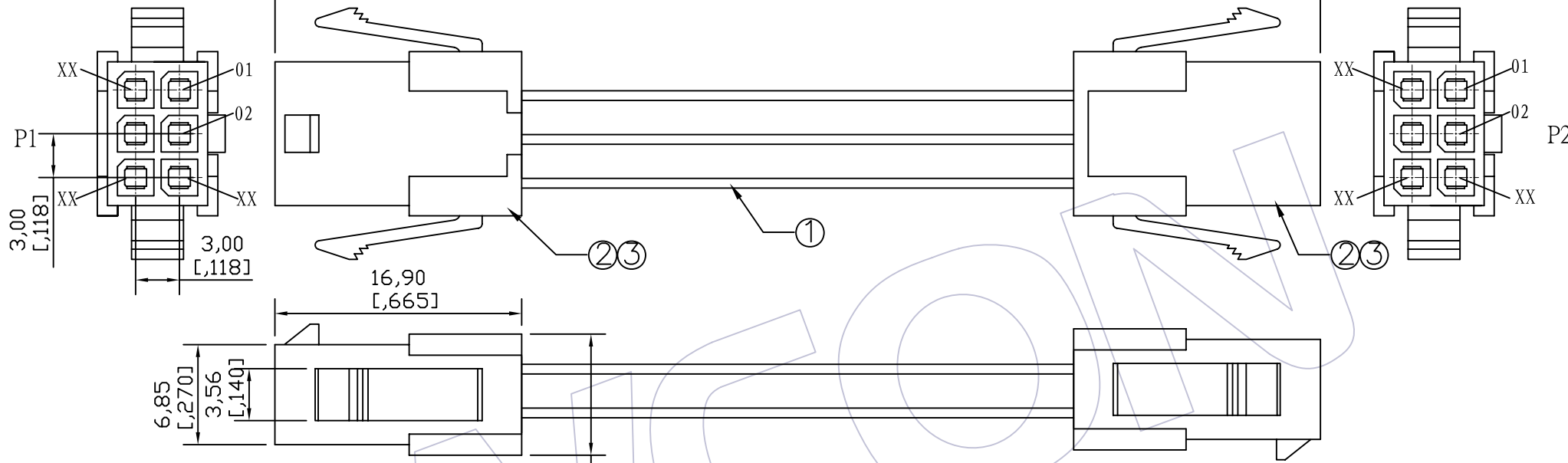

SPECIFICATIONS
 Insulation Resistance: 5MΩ Min
 Contact Resistance: 3.0Ω Max
 Withstand Voltage: DC 300V, 10S
 The Cable Assembly Must 100% Test

Ordering Information
C9190 - XX 02 xxx 341
 No. of Pins: 02~12P Shape Style: 02=Both ends process Length of Line

CONNECT METHOD

P1	Color	P2
01	XXX	01
02	XXX	02
03	XXX	03
XX	XXX	XX

Wire SPEC	LENGTH	TOLERANCE
ULxxxx 20~24AWG	1~499	±5
	500~999	±10
	1000~1500	±15
	1501~3000	±20
	3001~5000	±30
	5001~	± Lx1%

③	WF3001-Txxx0x	Terminal	3.00mm Phosphor Bronze/Brass Tin Terminal	Double xx	PCS
②	WF3001-2HxxB02	Housing	Dual Row PH3.00mm xxP Black Housing	2	PCS
①	Wxxxx-1xxx00001	WIRE	UL:xxxx,AWG:20~24,Color:xx,Wire	xxxx	MM
NO.	PART NO.	NAME	Specification	Q'TY	UNIT

AO		09/10/20	NEW			工程图 ENGINEERING	绘图 DRAW	BEN	09/10/20	SCALE	FREE	WCON 维峰五金电子有限公司 WAFE HARDWARE ELECTRONICS CO. LTD			
版次 REV	日期 DATE	变更说明 MODIFICATION DESCRIPTION		变更 CHANGE	核准 APPROVE	X.X ±0.30	设计 DESIGN			UNIT	mm	料号 PART NO.	C9190-xx02xxx341		
						X.XX ±0.20	审核 CHECK			SIZE	A4	品名 TITLE:	PH3.00 **P HSG TO PH3.00 **P HSG		
						X.XXX ±0.10	核准 APPROVE			SHEET	1/1	客户料号 Customer NO.			
						Angle ± 2'				PROJ.					
						DIM TOL									