

HSF

LENGTH±TOLERANCE

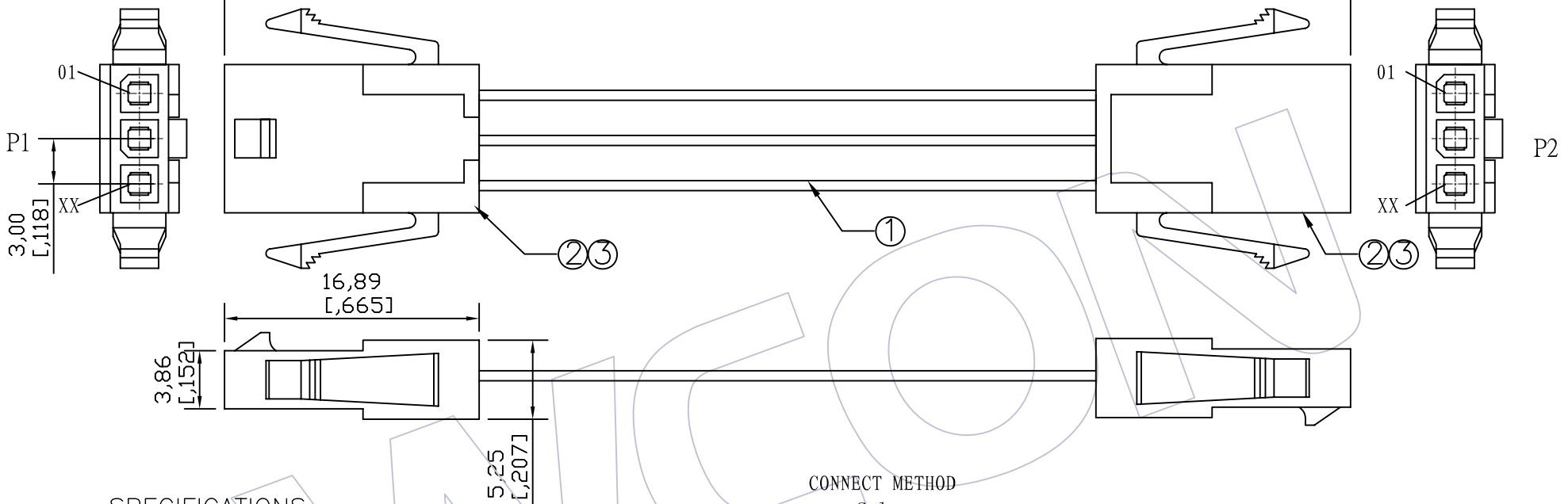

SPECIFICATIONS

Insulation Resistance: 5MΩ Min
 Contact Resistance: 3.0Ω Max
 Withstand Voltage: DC 300V, 10S
 The Cable Assembly Must 100% Test

CONNECT METHOD

P1	Color	P2
01	XXX	01
02	XXX	02
03	XXX	03
XX	XXX	XX

Wire SPEC	LENGTH	TOLERANCE
ULxxxx 20~24AWG	1~499	±5
	500~999	±10
	1000~1500	±15
	1501~3000	±20
	3001~5000	±30
	5001~	± Lx1%

Ordering Information

C9190 - XX 02 XXX 311

No.of Pins: 02~12P Shape Style: 02=Both ends Process Length of Line

NO.	PART NO.	NAME	Specification	Q' TY	UNIT
③	WF3001-Txxx0x	Terminal	3.00mm Phosphor Bronze/Brass Tin Terminal	Double xx	PCS
②	WF3001-1HxxB02	Housing	Single Row PH3.00mm xxP Black Housing	2	PCS
①	Wxxxx-1xxx00001	WIRE	UL:xxxx,AWG:20~24,Color:xx,Wire	xxxx	MM

AO	09/10/20	NEW				工程图 ENGINEERING	绘图 DRAW	BEN	09/10/20	SCALE	FREE	<p>维峰五金电子有限公司 WAFE HARDWARE ELECTRONICS CO. LTD</p>		
版次 REV	日期 DATE	变更说明 MODIFICATION DESCRIPTION	变更 CHANGE	核准 APPROVE		X.X	±0.30			UNIT	mm			
						X.XX	±0.20			SIZE	A4		料号 PART NO.	C9190-xx02xxx311
						X.XXX	±0.10			SHEET	1/1		品名 TITLE:	PH3.00 **P HSG TO PH3.00 **P HSG
						Angle	± 2'			PROJ.	客户料号Customer NO.			