

HSF

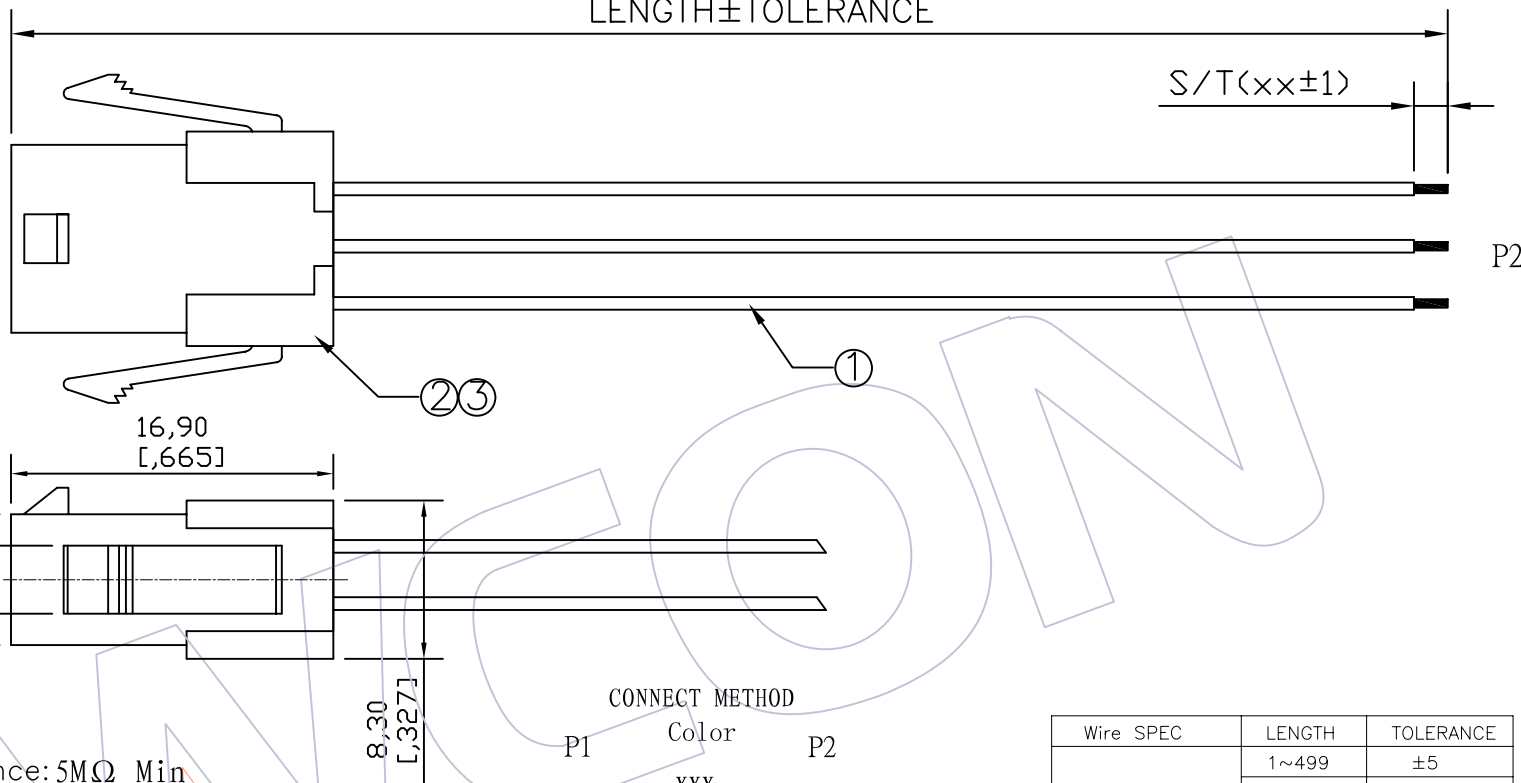
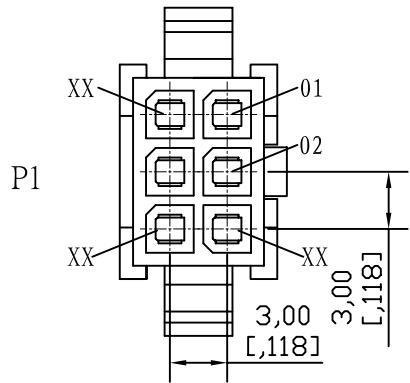

SPECIFICATIONS

Insulation Resistance: 5MΩ Min
 Contact Resistance: 3.0Ω Max
 Withstand Voltage: DC 300V, 10S
 The Cable Assembly Must 100% Test

Ordering Information

C9190 - xx 01 xxx 141

No.of Pins:
02~12P

Shape Style:
01=one end Process,
another one end plate tin

Length of Line

CONNECT METHOD

| | P1 | Color | P2 |
|----|-----|-------|------|
| 01 | XXX | | OPEN |
| 02 | XXX | | OPEN |
| 03 | XXX | | OPEN |
| XX | XXX | | OPEN |

| Wire SPEC | LENGTH | TOLERANCE |
|--------------------|-----------|-----------|
| ULxxxx 20~24AWG | 1~499 | ±5 |
| | 500~999 | ±10 |
| | 1000~1500 | ±15 |
| | 1501~3000 | ±20 |
| | 3001~5000 | ±30 |
| | 5001~ | ± Lx1% |

| NO. | PART NO. | NAME | Specification | Q' TY | UNIT |
|-----|-----------------|----------|---|-------|------|
| ③ | WF3001-Txxx0x | Terminal | 3.00mm Phosphor Bronze/Brass Tin Terminal | xx | PCS |
| ② | WF3001-2HxxB02 | Housing | Dual Row PH3.00mm xxP Black Housing | 1 | PCS |
| ① | Wxxxx-1xxx00001 | WIRE | UL:xxxx,AWG:20~24,Color:xx,Wire | xxxx | MM |

| | | | | | |
|--------------------|------------|---------------|----------|-------|------------------|
| 工程图 ENGINEERING | 绘图 DRAW | BEN | 09/10/20 | SCALE | FREE |
| X.X | ±0.30 | | | UNIT | mm |
| X.XX | ±0.20 | | | SIZE | A4 |
| X.XXX | ±0.10 | | | SHEET | 1/1 |
| Angle | ± 2' | | | PROJ. | 客户料号Customer NO. |
| DIM | TOL | 核准 APPROVE | | | |

| | |
|---|----------------------------|
| WCON 维峰五金电子有限公司 WAFE HARDWARE ELECTRONICS CO. LTD | |
| 料号 PART NO. | C9190-xx01xxx141 |
| 品名 TITLE: | PH3.00 **P Housing TO OPEN |
| 客户料号Customer NO. | |

| 版次 REV | 日期 DATE | 变更说明 MODIFICATION DESCRIPTION | 变更 CHANGE | 核准 APPROVE |
|-----------|------------|----------------------------------|--------------|---------------|
| AO | 09/10/20 | NEW | | |