

# HSF

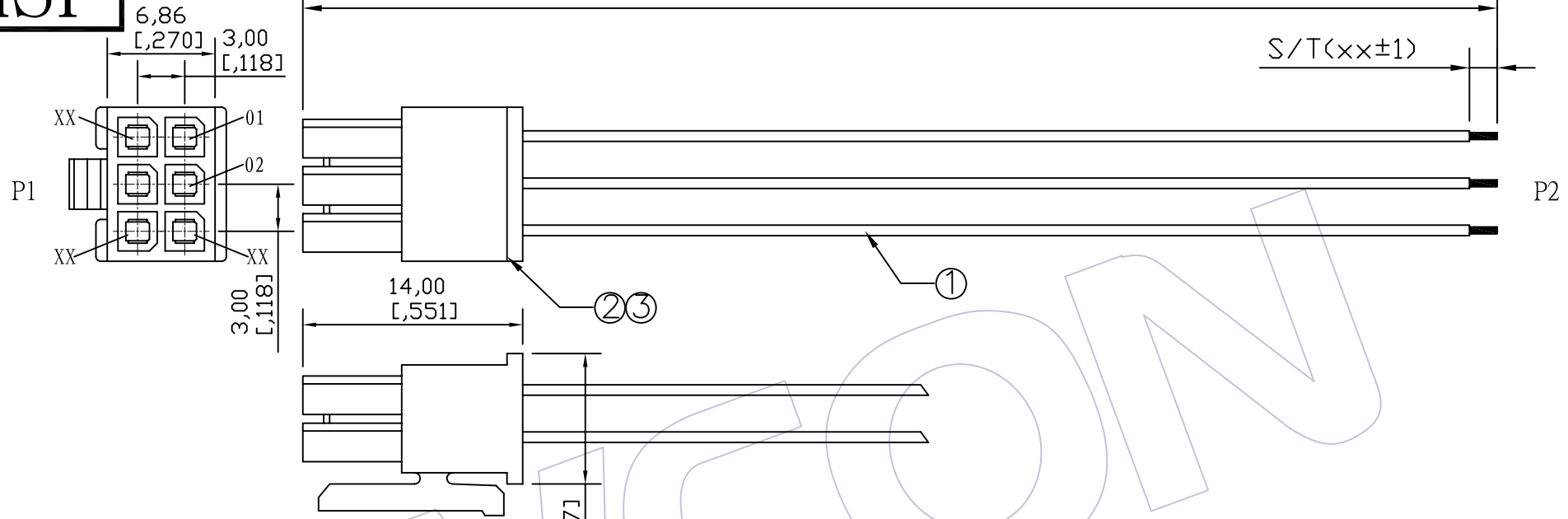

### SPECIFICATIONS

Insulation Resistance: 5MΩ Min  
 Contact Resistance: 3.0Ω Max  
 Withstand Voltage: DC 300V, 10S  
 The Cable Assembly Must 100% Test

### Ordering Information

C9190 - xx 01 xxx 131

No. of Pins: 02~12P  
 Shape Style: 01=one end Process, another one end plate tin  
 Length of Line

### CONNECT METHOD

P1	Color	P2
01	XXX	OPEN
02	XXX	OPEN
03	XXX	OPEN
XX	XXX	OPEN

Wire SPEC	LENGTH	TOLERANCE
ULxxxx 20~24AWG	1~499	±5
	500~999	±10
	1000~1500	±15
	1501~3000	±20
	3001~5000	±30
	5001~	± Lx1%

NO.	PART NO.	NAME	Specification	Q'TY	UNIT
③	WF3001-Txxx0x	Terminal	3.00mm Phosphor Bronze/Brass Tin Terminal	xx	PCS
②	WF3001-2HxxB01	Housing	Dual Row PH3.00mm xxP Black Housing	1	PCS
①	Wxxxx-1xxx00001	WIRE	UL:xxxx,AWG:20~24,Color:xx,Wire	xxxx	MM

AO		09/10/20	NEW			工程图 ENGINEERING	绘图 DRAW	BEN	09/10/20	SCALE	FREE	<b>WCON</b> 维峰五金电子有限公司 WAFE HARDWARE ELECTRONICS CO. LTD	
版次 REV	日期 DATE	变更说明 MODIFICATION DESCRIPTION		变更 CHANGE	核准 APPROVE	X.X ±0.30	设计 DESIGN			UNIT	mm		
						X.XX ±0.20	审核 CHECK			SIZE	A4	品名 TITLE:	PH3.00 **P Housing TO OPEN
						X.XXX ±0.10	核准 APPROVE			SHEET	1/1	客户料号Customer NO.	
						Angle ± 2'				PROJ.	客户料号Customer NO.		
						DIM TOL							