

# HSF

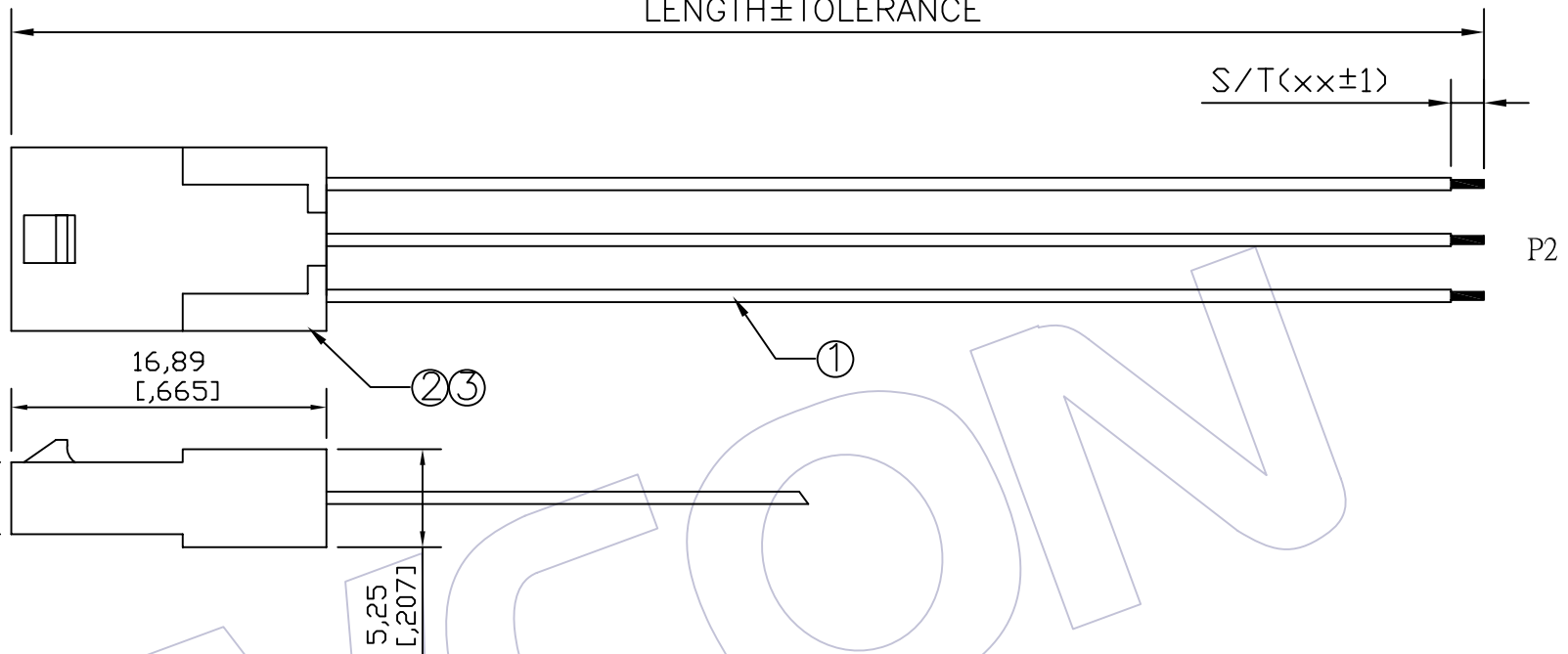
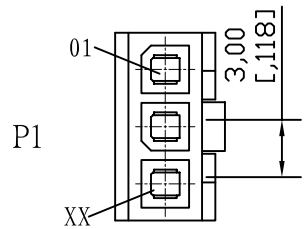

### SPECIFICATIONS

Insulation Resistance: 5MΩ Min  
 Contact Resistance: 3.0Ω Max  
 Withstand Voltage: DC 300V, 10S  
 The Cable Assembly Must 100% Test

### Ordering Information

C9190 - xx 01 xxx 121

No. of Pins: 02~12P      Shape Style: 01=one end Process, another one end plate tin  
 Length of Line

CONNECT METHOD		
P1	Color	P2
01	XXX	OPEN
02	XXX	OPEN
03	XXX	OPEN
XX	XXX	OPEN

Wire SPEC	LENGTH	TOLERANCE
ULxxxx 20~24AWG	1~499	±5
	500~999	±10
	1000~1500	±15
	1501~3000	±20
	3001~5000	±30
	5001~	± Lx1%

NO.	PART NO.	NAME	Specification	Q'TY	UNIT
③	WF3001-Txxx0x	Terminal	3.00mm Phosphor Bronze/Brass Tin Terminal	xx	PCS
②	WF3001-1HxxB03	Housing	Single Row PH3.00mm xxP Black Housing	1	PCS
①	Wxxxx-1xxx00001	WIRE	UL:xxxx,AWG:20~24,Color:xx,Wire	xxxx	MM

工程图 ENGINEERING		绘图 DRAW		BEN	09/10/20	SCALE	FREE	维峰五金电子有限公司 WAFE HARDWARE ELECTRONICS CO. LTD	
X.X	±0.30	设计 DESIGN				UNIT	mm		
X.XX	±0.20	审核 CHECK				SIZE	A4	料号 PART NO.	C9190-xx01xxx121
X.XXX	±0.10	核准 APPROVE				SHEET	1/1	品名 TITLE:	PH3.00 **P Housing TO OPEN
版次 REV	日期 DATE	变更说明 MODIFICATION DESCRIPTION		变更 CHANGE	核准 APPROVE	Angle	± 2'	客户料号Customer NO.	
		DIM		TOL	APPROVE	PROJ.			