

HSF

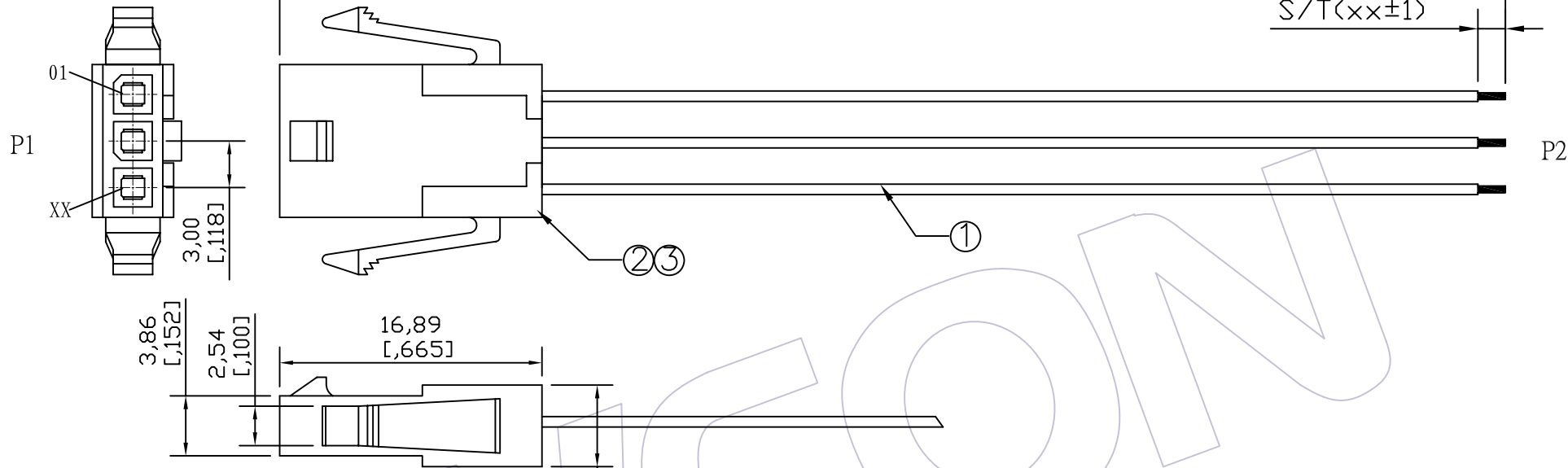

SPECIFICATIONS

Insulation Resistance: 5M Ω Min
 Contact Resistance: 3.0 Ω Max
 Withstand Voltage: DC 300V, 10S
 The Cable Assembly Must 100% Test

Ordering Information

C9190 - xx 01 xxx 111

No. of Pins: 02~12P
 Shape Style: 01=one end Process, another one end plate tin
 Length of Line

CONNECT METHOD

P1	Color	P2
01	XXX	OPEN
02	XXX	OPEN
03	XXX	OPEN
XX	XXX	OPEN

Wire SPEC	LENGTH	TOLERANCE
ULxxxx 20~24AWG	1~499	± 5
	500~999	± 10
	1000~1500	± 15
	1501~3000	± 20
	3001~5000	± 30
	5001~	$\pm L \times 1\%$

NO.	PART NO.	NAME	Specification	Q'TY	UNIT
③	WF3001-Txxx0x	Terminal	3.00mm Phosphor Bronze/Brass Tin Terminal	xx	PCS
②	WF3001-1HxxB02	Housing	Single Row PH3.00mm xxP Black Housing	1	PCS
①	Wxxxx-1xxx00001	WIRE	UL:xxxx,AWG:20~24,Color:xx,Wire	xxxx	MM

A0		09/10/20	NEW			工程图 ENGINEERING	绘图 DRAW	BEN	09/10/20	SCALE	FREE	WCON 维峰五金电子有限公司 WAFE HARDWARE ELECTRONICS CO. LTD	
版次 REV	日期 DATE	变更说明 MODIFICATION DESCRIPTION		变更 CHANGE	核准 APPROVE	X.X ± 0.30	设计 DESIGN			UNIT	mm		
						X.XX ± 0.20	审核 CHECK			SIZE	A4	品名 TITLE:	PH3.00 **P Housing TO OPEN
						X.XXX ± 0.10	核准 APPROVE			SHEET	1/1	客户料号 Customer NO.	
						Angle $\pm 2'$				PROJ.			
						DIM TOL							