

HSF

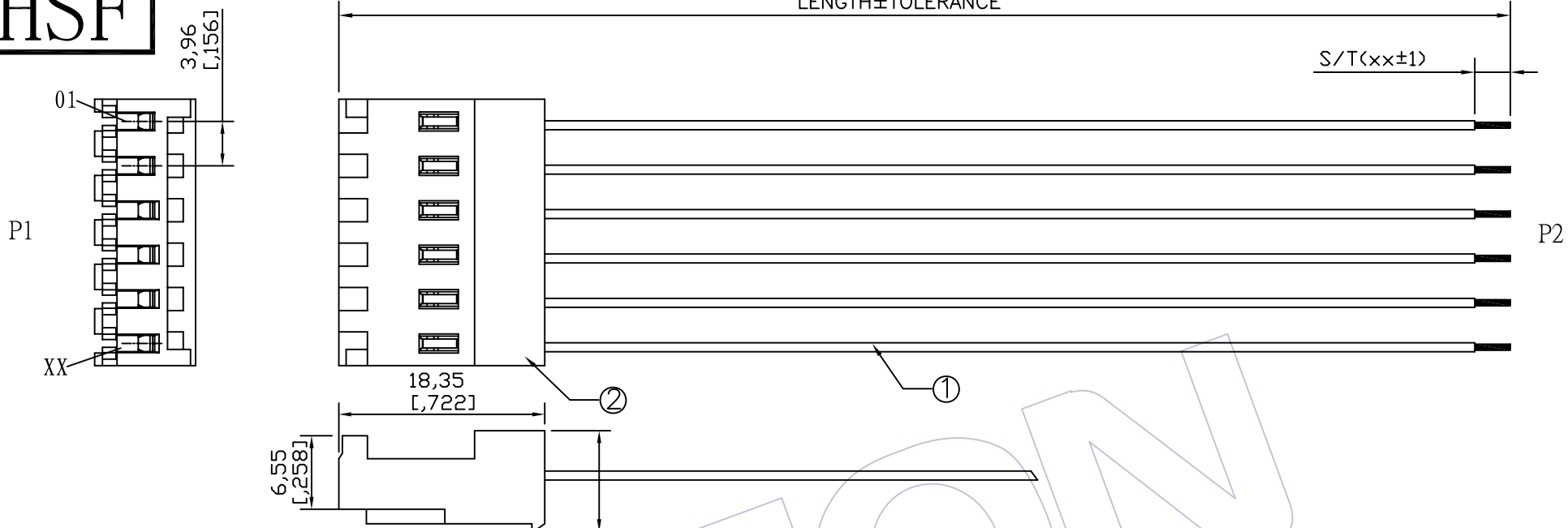

SPECIFICATIONS

Insulation Resistance: 5MΩ Min
 Contact Resistance: 3.0Ω Max
 Withstand Voltage: DC 300V, 10S
 The Cable Assembly Must 100% Test

Ordering Information

C9150 - xx 01 xxx 201

No. of Pins: 02~20P
 Shape Style: 01=one end Process, another one end plate tin
 Length of Line

CONNECT METHOD		
P1	Color	P2
01	XXX	OPEN
02	XXX	OPEN
03	XXX	OPEN
XX	XXX	OPEN

Wire SPEC	LENGTH	TOLERANCE
ULxxxx 18~24AWG	1~499	±5
	500~999	±10
	1000~1500	±15
	1501~3000	±20
	3001~5000	±30
	5001~	± Lx1%

②	WF3964-Hxxx01	Housing	3.96mm xxP Housing 90°(IDC TYPE)	1	PCS
①	Wxxxx-1xxx00001	WIRE	UL:xxxx,AWG:18~24,Color:xx,Wire	xxxx	MM
NO.	PART NO.	NAME	Specification	Q'TY	UNIT

						工程图 ENGINEERING	绘图 DRAW	BEN	09/10/22	SCALE	FREE	WCON 维峰五金电子有限公司 WAFE HARDWARE ELECTRONICS CO. LTD 料号 PART NO. C9150-xx01xx201 品名 TITLE: PH3.96 **P Housing TO OPEN 客户料号Customer NO.
						X.X	±0.30			UNIT	mm	
						X.XX	±0.20			SIZE	A4	
						X.XXX	±0.10			SHEET	1/1	
AO	09/10/22	NEW				Angle	± 2'			PROJ.	客户料号Customer NO.	
版次 REV	日期 DATE	变更说明 MODIFICATION DESCRIPTION	变更 CHANGE	核准 APPROVE		DIM	TOL	核准 APPROVE				