

HSF

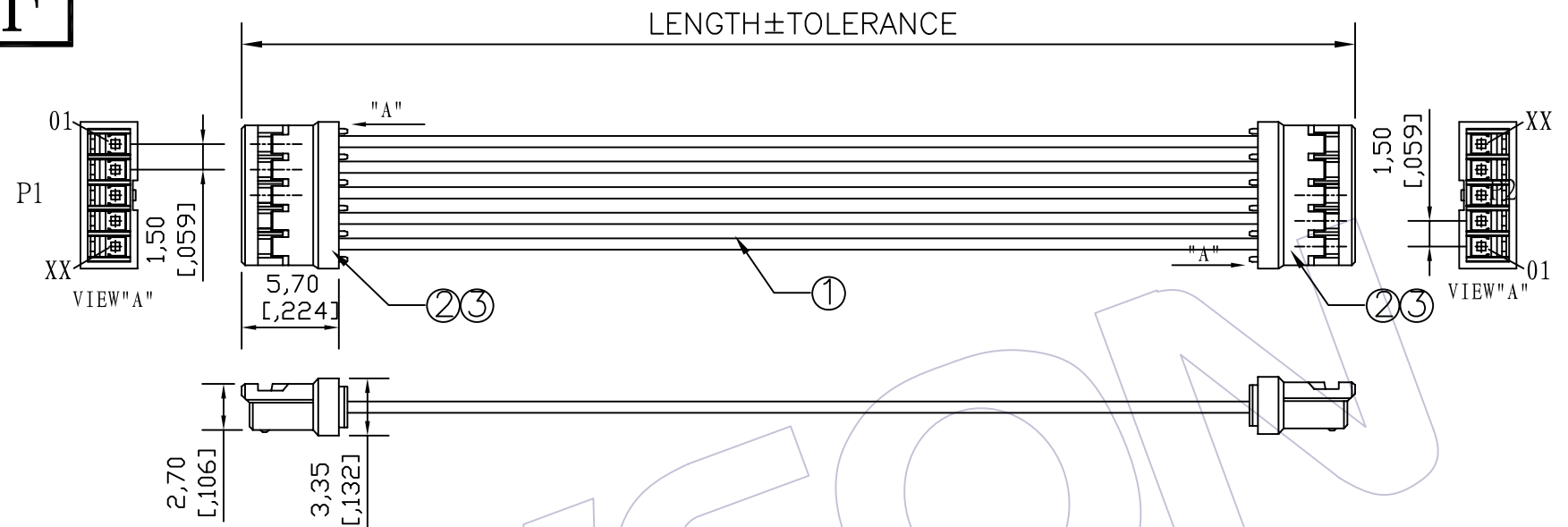

SPECIFICATIONS
 Insulation Resistance: 5MΩ Min
 Contact Resistance: 3.0Ω Max
 Withstand Voltage: DC 300V, 10S
 The Cable Assembly Must 100% Test

CONNECT METHOD

P1	Color	P2
01	XXX	XX
02	XXX	XX
03	XXX	XX
	⋮	
XX	XXX	01

Wire SPEC	LENGTH	TOLERANCE
ULxxxx 28~32AWG	1~499	±5
	500~999	±10
	1000~1500	±15
	1501~3000	±20
	3001~5000	±30
	5001~	± Lx1%

Ordering Information

C9190 - xx 02 xxx 201

No. of Pins: 02~15P Shape Style: 02=Both ends Process Length of Line

③	WF1502-TPSN01	Terminal	PH1.50mm Phosphor Bronze Tin Terminal	Double xx	PCS
②	WF1502-HxxW01	Housing	PH1.50mm xxP White Housing	2	PCS
①	Wxxxx-1xxx00001	WIRE	UL: xxxx, AWG: 28-32, Color: xx, Wire	xxxx	MM
NO.	PART NO.	NAME	Specification	Q'TY	UNIT

					工程图 ENGINEERING	绘图 DRAW	BEN	09/10/12	SCALE	FREE	 WCON 维峰五金电子有限公司 WAFE HARDWARE ELECTRONICS CO. LTD	
					X.X	±0.30			UNIT	mm		
					X.XX	±0.20			SIZE	A4		
					X.XXX	±0.10			SHEET	1/1		
					Angle	± 2'			PROJ.	客户料号Customer NO.		
AO	09/10/12				变更说明 MODIFICATION DESCRIPTION	变更 CHANGE	核准 APPROVE				料号 PART NO.	C9190-xx02xxx201
版次 REV	日期 DATE										品名 TITLE:	PH1.50 **P HSG TO PH1.50 **P HSG