

HSF

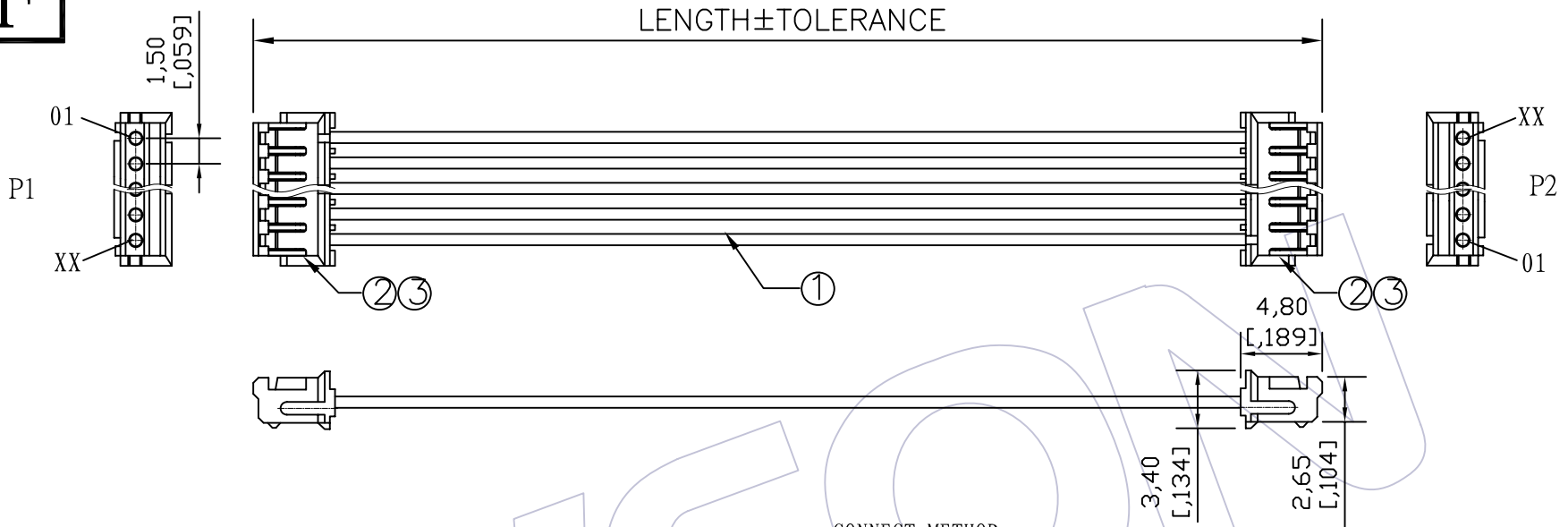

SPECIFICATIONS
 Insulation Resistance: 5MΩ Min
 Contact Resistance: 3.0Ω Max
 Withstand Voltage: DC 300V, 10S
 The Cable Assembly Must 100% Test

CONNECT METHOD

| P1 | Color | P2 |
|----|-------|----|
| 01 | XXX | XX |
| 02 | XXX | XX |
| 03 | XXX | XX |
| | ⋮ | |
| XX | XXX | 01 |

| Wire SPEC | LENGTH | TOLERANCE |
|--------------------|-----------|-----------|
| ULxxxx 28~32AWG | 1~499 | ±5 |
| | 500~999 | ±10 |
| | 1000~1500 | ±15 |
| | 1501~3000 | ±20 |
| | 3001~5000 | ±30 |
| | 5001~ | ± Lx1% |

Ordering Information

C9190 - xx 02 xxx 101

No. of Pins: 02~15P Shape Style: 02=Both ends Process Length of Line

| ③ | WF1501-TPSN01 | Terminal | PH1.50mm Phosphor Bronze Tin Terminal | Double xx | PCS |
|-----|-----------------|----------|---------------------------------------|-----------|------|
| ② | WF1501-HxxW01 | Housing | PH1.50mm xxP White Housing | 2 | PCS |
| ① | Wxxxx-1xxx00001 | WIRE | UL: xxxx, AWG: 28-32, Color: xx, Wire | xxxx | MM |
| NO. | PART NO. | NAME | Specification | Q' TY | UNIT |

| | | | | | | | | | | | | | | |
|-----------|------------|----------------------------------|-----|--------------|---------------|--------------------|------------|---------------|----------|-------|-------------------|-------------------------------------------------------------|-------------|----------------------------------|
| A0 | | 09/10/12 | NEW | | | 工程图 ENGINEERING | 绘图 DRAW | BEN | 09/10/12 | SCALE | FREE | WCON 维峰五金电子有限公司 WAFE HARDWARE ELECTRONICS CO. LTD | | |
| 版次 REV | 日期 DATE | 变更说明 MODIFICATION DESCRIPTION | | 变更 CHANGE | 核准 APPROVE | X.X | ±0.30 | | | UNIT | mm | | | |
| | | | | | | X.XX | ±0.20 | | | SIZE | A4 | | 料号 PART NO. | C9190-xx02xxx101 |
| | | | | | | X.XXX | ±0.10 | | | SHEET | 1/1 | | 品名 TITLE: | PH1.50 **P HSG TO PH1.50 **P HSG |
| | | | | | | Angle | ± 2' | | | PROJ. | 客户料号 Customer NO. | | | |
| | | | | | | DIM | TOL | 核准 APPROVE | | | | | | |