

HSF

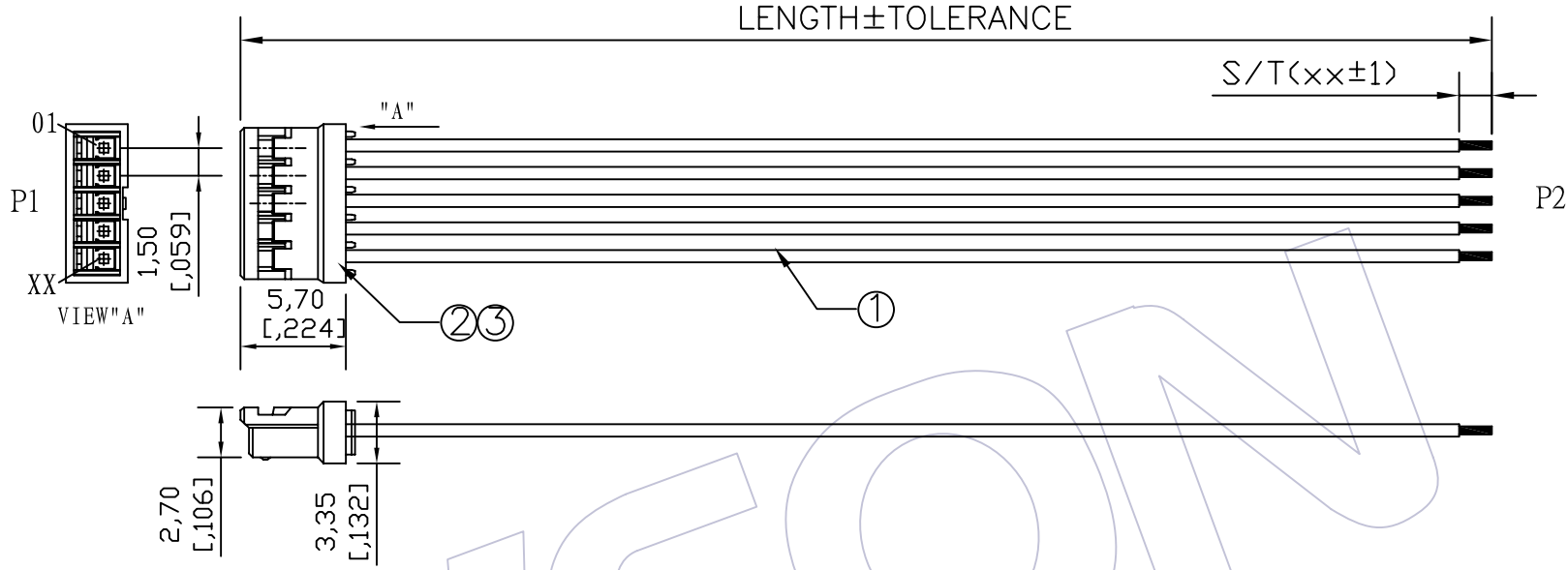

SPECIFICATIONS
 Insulation Resistance: 5MΩ Min
 Contact Resistance: 3.0Ω Max
 Withstand Voltage: DC 300V, 10S
 The Cable Assembly Must 100% Test

CONNECT METHOD

| P1 | Color | P2 |
|----|-------|------|
| 01 | XXX | OPEN |
| 02 | XXX | OPEN |
| 03 | XXX | OPEN |
| XX | XXX | OPEN |

| Wire SPEC | LENGTH | TOLERANCE |
|--------------------|-----------|-----------|
| ULxxxx 28~32AWG | 1~499 | ±5 |
| | 500~999 | ±10 |
| | 1000~1500 | ±15 |
| | 1501~3000 | ±20 |
| | 3001~5000 | ±30 |
| | 5001~ | ± Lx1% |

Ordering Information

C9190 - xx 01 xxx 011

No. of Pins: 02~20P Shape Style: 01=one end Process, another one end plate tin Length of Line

| NO. | PART NO. | NAME | Specification | Q' TY | UNIT |
|-----|-----------------|----------|---------------------------------------|-------|------|
| ③ | WF1502-TPSN01 | Terminal | PH1.50mm Phosphor Bronze Tin Terminal | xx | PCS |
| ② | WF1502-HxxW01 | Housing | PH1.50mm xxP White Housing | 1 | PCS |
| ① | Wxxxx-1xxx00001 | WIRE | UL: xxxx, AWG: 28-32, Color: xx, Wire | xxxx | MM |

| REV | DATE | MODIFICATION DESCRIPTION | CHANGE | APPROVE | ENGINEERING | DRAW | DATE | SCALE | UNIT | SHEET | PROJ. | Customer NO. |
|-----|----------|--------------------------|--------|---------|-------------|------|----------|-------|------|-------|-------|--------------|
| A0 | 09/10/12 | NEW | | | X.X ±0.30 | BEN | 09/10/12 | FREE | mm | 1/1 | | |
| | | | | | X.XX ±0.20 | | | | | | | |
| | | | | | X.XXX ±0.10 | | | | | | | |
| | | | | | Angle ± 2' | | | | | | | |
| | | | | | DIM TOL | | | | | | | |

WCON 维峰五金电子有限公司
 WAVE HARDWARE ELECTRONICS CO. LTD

料号 PART NO. C9190-xx01xxx011
 品名 TITLE: PH1.50 **P Housing TO OPEN

客户料号 Customer NO.