

HSF

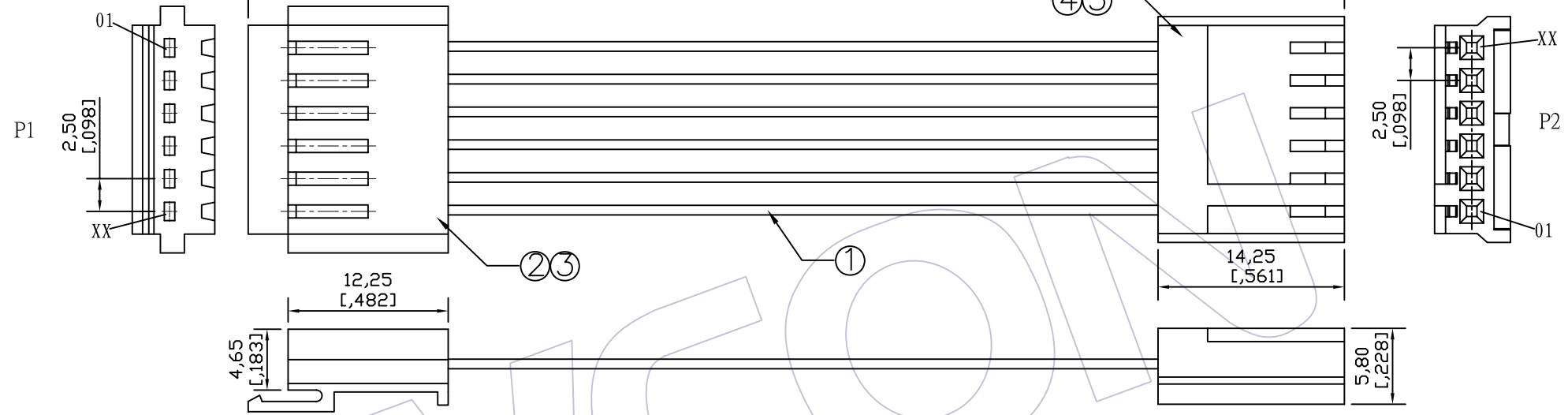

SPECIFICATIONS

Insulation Resistance: 5MΩ Min
 Contact Resistance: 3.0Ω Max
 Withstand Voltage: DC 300V, 10S
 The Cable Assembly Must 100% Test

CONNECT METHOD

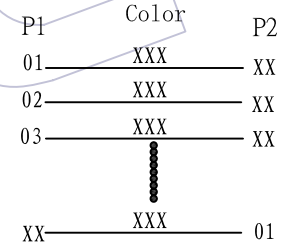

Wire SPEC	LENGTH	TOLERANCE
ULxxxx 22~26AWG	1~499	±5
	500~999	±10
	1000~1500	±15
	1501~3000	±20
	3001~5000	±30
	5001~	± Lx1%

Ordering Information

C9130 - xx 02 xxx 401

No. of Pins: 02~15P Shape Style: 02=Both ends Process Length of Line

NO.	PART NO.	NAME	Specification	Q' TY	UNIT
⑤	WF2510-TBSN01	Terminal	PH2.50mm Brass Tin Terminal	xx	PCS
④	WF2510-HxxW01	Housing	PH2.50mm xxP White Housing	1	PCS
③	WF2508-TPSN01	Terminal	PH2.50mm Phosphor Bronze Tin Terminal	xx	PCS
②	WF2508-HxxW01	Housing	PH2.50mm xxP White Housing	1	PCS
①	Wxxxx-1xxx00001	WIRE	UL: xxxx, AWG: 22~26, Color: xx, Wire	xxxx	MM

A0		09/09/28	NEW			工程图 ENGINEERING	绘图 DRAW	BEN	09/09/28	SCALE	FREE	WCON 维峰五金电子有限公司 WAFE HARDWARE ELECTRONICS CO. LTD	
版次 REV	日期 DATE	变更说明 MODIFICATION DESCRIPTION	变更 CHANGE	核准 APPROVE		X.X ±0.30	设计 DESIGN			UNIT	mm		
						X.XX ±0.20	审核 CHECK			SIZE	A4	品名 TITLE:	PH2.50 **P HSG/PH2.50 **P HSG
						X.XXX ±0.10	核准 APPROVE			SHEET	1/1	客户料号Customer NO.	
						Angle ± 2'				PROJ.	↗		
						DIM TOL							