

HSF

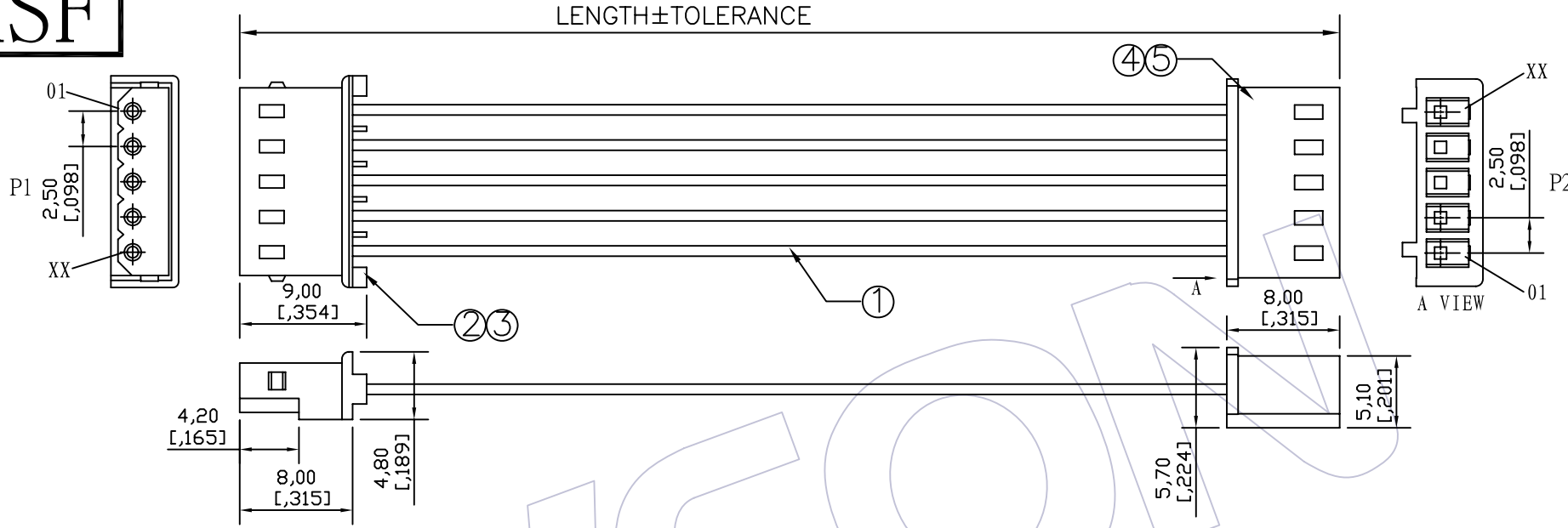

SPECIFICATIONS

Insulation Resistance: 5MΩ Min
 Contact Resistance: 3.0Ω Max
 Withstand Voltage: DC 300V, 10S
 The Cable Assembly Must 100% Test

CONNECT METHOD

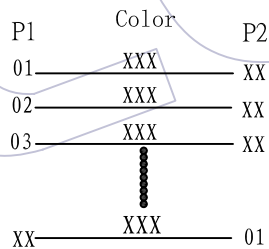

Wire SPEC	LENGTH	TOLERANCE
ULxxxx 22~28AWG	1~499	±5
	500~999	±10
	1000~1500	±15
	1501~3000	±20
	3001~5000	±30
	5001~	± Lx1%

Ordering Information

C9130 - xx 02 xxx 301

No. of Pins: 02~15P Shape Style: 02=Both ends Process Length of Line

NO.	PART NO.	NAME	Specification	Q' TY	UNIT
⑤	WF2503-TXSN01	Terminal	PH2.50mm Phosphor Bronze/Brass Tin Terminal	xx	PCS
④	WF2503-HxxE01	Housing	PH2.50mm xxP BEIGE Housing	1	PCS
③	WF2502-TPSN01	Terminal	PH2.50mm Phosphor Bronze Tin Terminal	xx	PCS
②	WF2502-HxxE01	Housing	PH2.50mm xxP BEIGE Housing	1	PCS
①	Wxxxx-1xxx00001	WIRE	UL: xxxx, AWG: 22~28, Color: xx, Wire	xxxx	MM

REV		DATE	MODIFICATION DESCRIPTION	CHANGE	APPROVE	ENGINEERING	DRAW	SCALE	FREE	WCON 维峰五金电子有限公司 WAFE HARDWARE ELECTRONICS CO. LTD	
A0	09/09/24		NEW			X.X ±0.30	设计	BEN	09/09/24	UNIT	mm
						X.XX ±0.20	DESIGN			SIZE	A4
						X.XXX ±0.10	审核			SHEET	1/1
						Angle ± 2'	CHECK			料号 PART NO. C9130-xx02xxx301	
						DIM TOL	核准			品名 TITLE: PH2.50 **P HSG/PH2.50 **P HSG	
							APPROVE			PROJ.	客户料号 Customer NO.