

HSF

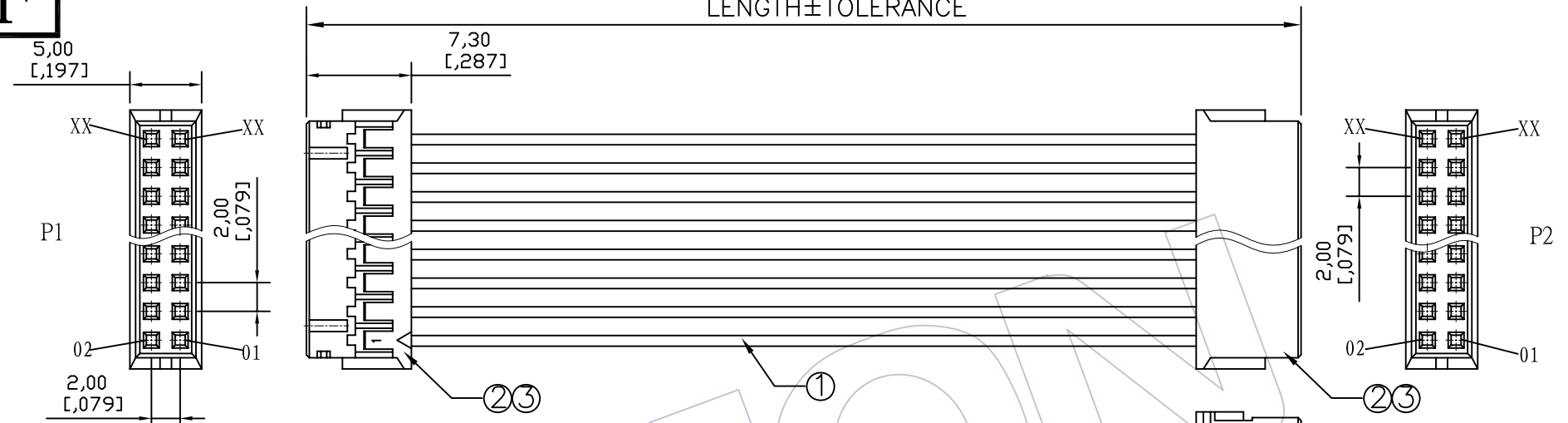

SPECIFICATIONS
 Insulation Resistance: 5MΩ Min
 Contact Resistance: 3.0Ω Max
 Withstand Voltage: DC 300V, 10S
 The Cable Assembly Must 100% Test

CONNECT METHOD

| | | |
|----|-------|----|
| P1 | Color | P2 |
| 01 | XXX | 01 |
| 02 | XXX | 02 |
| 03 | XXX | 03 |
| | ● | |
| XX | XXX | XX |

| Wire SPEC | LENGTH | TOLERANCE |
|--------------------|-----------|-----------|
| ULxxxx 22~28AWG | 1~499 | ±5 |
| | 500~999 | ±10 |
| | 1000~1500 | ±15 |
| | 1501~3000 | ±20 |
| | 3001~5000 | ±30 |
| | 5001~ | ± Lx1% |

Ordering Information
C9120 - xx 02 xxx 201

No. of Pins: 02~15P Shape Style: 02=Both ends Process Length of Line

| ③ | WF2002-TPSN01 | Terminal | PH2.00mm Phosphor Bronze Tin Terminal | Double xx | PCS |
|-----|-----------------|----------|---------------------------------------|-----------|------|
| ② | WF2002-HxxW01 | Housing | PHD xxP PH2.0mm White Housing | 2 | PCS |
| ① | Wxxxx-1xxx00001 | WIRE | UL: xxxx, AWG: 22~28, Color: xx, Wire | xxxx | MM |
| NO. | PART NO. | NAME | Specification | Q' TY | UNIT |

| | | | | | | | | | | | | |
|-----------|------------|----------------------------------|--------------|---------------|--|--------------------|---------------|-----|----------|-------|-------------------|--|
| AO | 09/09/24 | NEW | | | | 工程图 ENGINEERING | 绘图 DRAW | BEN | 09/09/24 | SCALE | FREE | WCON 维峰五金电子有限公司 WAFE HARDWARE ELECTRONICS CO. LTD 料号 PART NO. C9120-xx02xxx201 品名 TITLE: PH2.00 **P HSG TO PH2.00 **P HSG 客户料号 Customer NO. |
| 版次 REV | 日期 DATE | 变更说明 MODIFICATION DESCRIPTION | 变更 CHANGE | 核准 APPROVE | | X.X ±0.30 | 设计 DESIGN | | | UNIT | mm | |
| | | | | | | X.XX ±0.20 | 审核 CHECK | | | SIZE | A4 | |
| | | | | | | X.XXX ±0.10 | 核准 APPROVE | | | SHEET | 1/1 | |
| | | | | | | Angle ± 2' | | | | PROJ. | 客户料号 Customer NO. | |
| | | | | | | DIM TOL | | | | | | |