

HSF

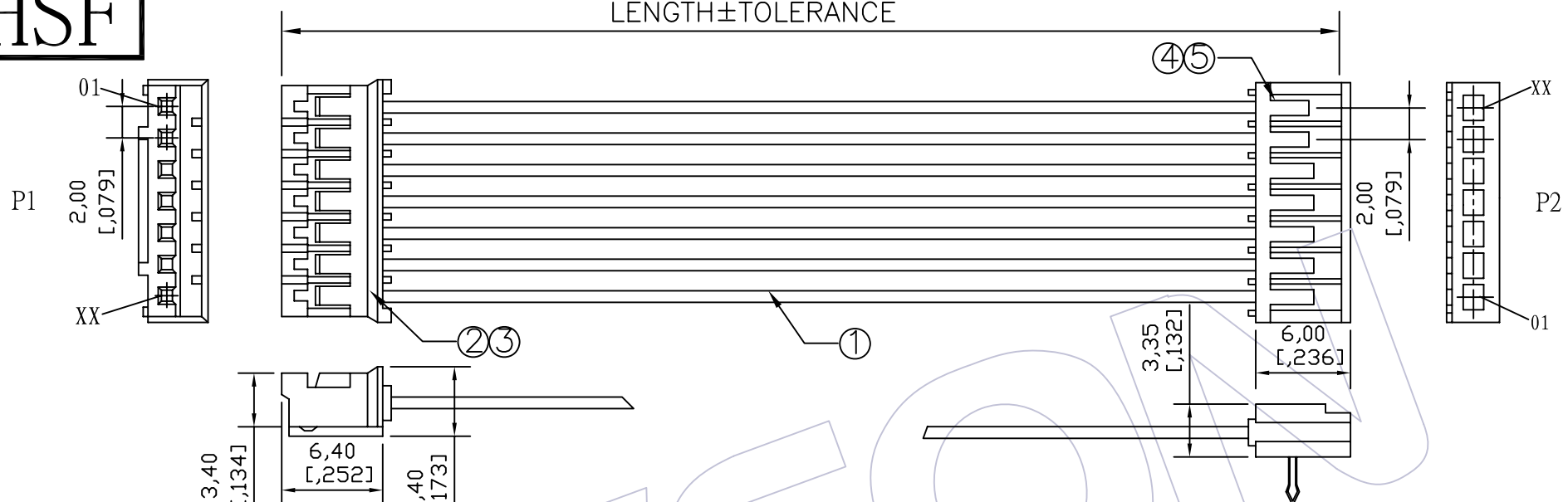

SPECIFICATIONS
 Insulation Resistance: 5MΩ Min
 Contact Resistance: 3.0Ω Max
 Withstand Voltage: DC 300V, 10S
 The Cable Assembly Must 100% Test

CONNECT METHOD

P1	Color	P2
01	XXX	XX
02	XXX	XX
03	XXX	XX
XX	XXX	01

Wire SPEC	LENGTH	TOLERANCE
ULxxxx 24~30AWG	1~499	±5
	500~999	±10
	1000~1500	±15
	1501~3000	±20
	3001~5000	±30
	5001~	± Lx1%

Ordering Information

C9120 - XX 02 XXX 102

No. of Pins: 02~30P Shape Style: 02=Both ends Process Length of Line

NO.	PART NO.	NAME	Specification	Q'TY	UNIT
⑤	WF2004-TBSN02	Terminal	PH2.00mm Brass Tin 90° Terminal	XX	PCS
④	WF2004-HxxW02	Housing	PH2.00mm xxP 90° White Housing	1	PCS
③	WF2001-TPSN01	Terminal	JST PH2.00mm Phosphor Bronze Tin Terminal	XX	PCS
②	WF2001-HxxW01	Housing	JST PH2.00mm xxP White Housing	1	PCS
①	Wxxxx-1xxx00001	WIRE	UL: xxxx, AWG: 24~30, Color: xx, Wire	XXXX	MM

AO	09/09/24	NEW				工程图 ENGINEERING	绘图 DRAW	BEN	09/09/24	SCALE	FREE	WCON 维峰五金电子有限公司 WAFE HARDWARE ELECTRONICS CO. LTD 料号 PART NO. C9120-xx02xxx102 品名 TITLE: PH2.00 **P HSG TO PH2.00 **P HSG 客户料号 Customer NO.
版次 REV	日期 DATE	变更说明 MODIFICATION DESCRIPTION	变更 CHANGE	核准 APPROVE		X.X ±0.30	设计 DESIGN			UNIT	mm	
						X.XX ±0.20	审核 CHECK			SIZE	A4	
						X.XXX ±0.10	核准 APPROVE			SHEET	1/1	
						Angle ± 2'				PROJ.	客户料号 Customer NO.	
						DIM TOL						