

HSF

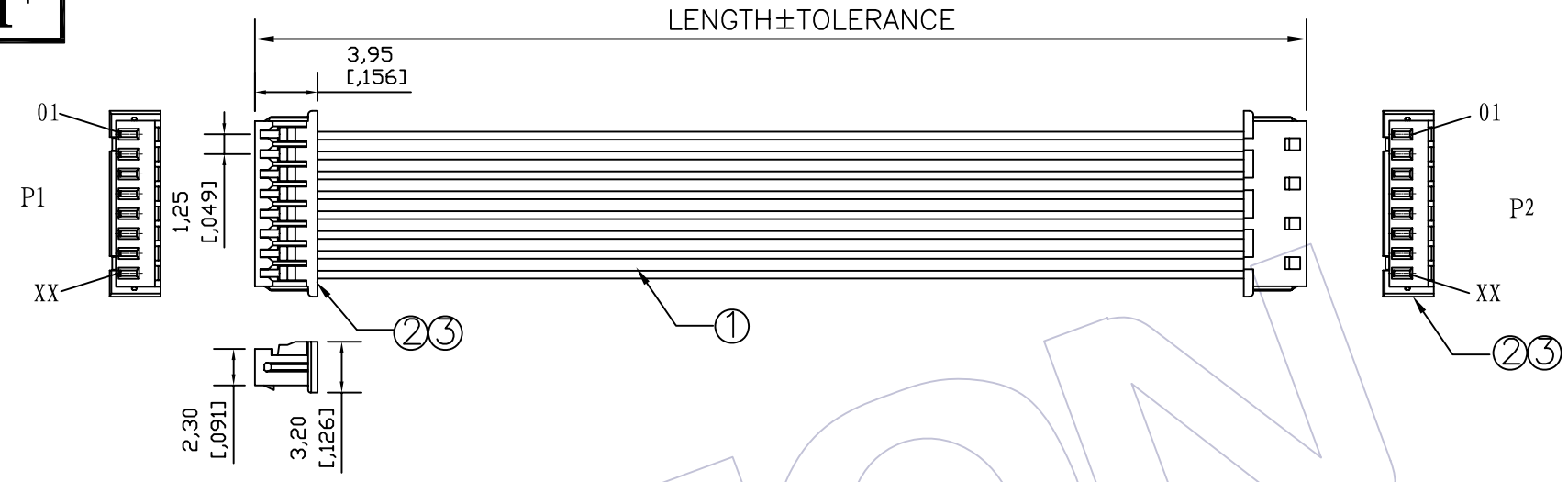

SPECIFICATIONS
 Insulation Resistance: 5MΩ Min
 Contact Resistance: 3.0Ω Max
 Withstand Voltage: DC 300V, 10S
 The Cable Assembly Must 100% Test

CONNECT METHOD

P1	Color	P2
01	XXX	01
02	XXX	02
03	XXX	03
XX	XXX	XX

Wire SPEC	LENGTH	TOLERANCE
ULxxxx 28~32AWG	1~499	±5
	500~999	±10
	1000~1500	±15
	1501~3000	±20
	3001~5000	±30
	5001~	± Lx1%

Ordering Information

C9110 - xx 02 xxx 401

No. of Pins: 02~16P Shape Style: 02=Both ends Process Length of Line

NO.	PART NO.	NAME	Specification	Q' TY	UNIT
③	WF1251-TPSN01	Terminal	PH1.25mm Phosphor Bronze Tin Terminal	Double xx	PCS
②	WF1251-HxxW01	Housing	PH1.25mm xxP White Housing	2	PCS
①	Wxxxx-1xxx00001	WIRE	UL: xxxx, AWG: 28-32, Color: xx, Wire	xxxx	MM

REV	DATE	MODIFICATION DESCRIPTION	CHANGE	APPROVE	SCALE	UNIT	SHEET	PROJ.	CUSTOMER NO.
A0	09/09/10	NEW			free	mm	1/1	客户料号Customer NO.	

WCON 维峰五金电子有限公司
 WAFE HARDWARE ELECTRONICS CO. LTD

料号 PART NO. C9110-xx02xxx401
 品名 TITLE: PH1.25 **P Housing/PH1.25 xxP Housing