

HSF

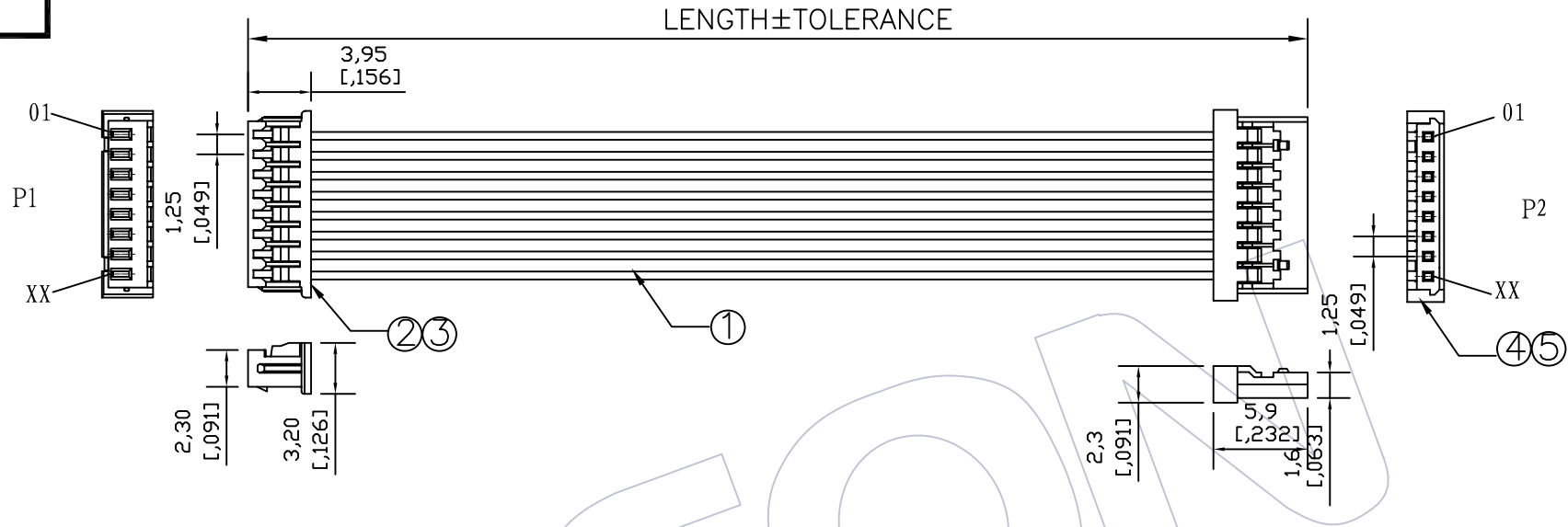

SPECIFICATIONS

Insulation Resistance: 5MΩ Min
 Contact Resistance: 3.0Ω Max
 Withstand Voltage: DC 300V, 10S
 The Cable Assembly Must 100% Test

CONNECT METHOD

P1	Color	P2
01	XXX	01
02	XXX	02
03	XXX	03
XX	XXX	XX

Wire SPEC	LENGTH	TOLERANCE
ULxxxx 28~32AWG	1~499	±5
	500~999	±10
	1000~1500	±15
	1501~3000	±20
	3001~5000	±30
	5001~	± Lx1%

Ordering Information

C9110 - XX 02 XXX 301

No. of Pins: 02~16P Shape Style: 02=Both ends Process Length of Line

⑤	WF1255-TPSN01	Terminal	PH1.25mm Phosphor Bronze Tin Terminal	xx	PCS
④	WF1255-Hxxx01	Housing	PH1.25mm xxP Color: xx Housing	1	PCS
③	WF1251-TPSN01	Terminal	PH1.25mm Phosphor Bronze Tin Terminal	xx	PCS
②	WF1251-HxxW01	Housing	PH1.25mm xxP White Housing	1	PCS
①	Wxxxx-1xxx00001	WIRE	UL: xxxx, AWG: 28-32, Color: xx, Wire	xxxx	MM
NO.	PART NO.	NAME	Specification	Q' TY	UNIT

						工程图 ENGINEERING	绘图 DRAW	BEN	09/09/10	SCALE	free	WCON 维峰五金电子有限公司 WAFE HARDWARE ELECTRONICS CO. LTD 料号 PART NO. C9110-xx02xxx301 品名 TITLE: PH1.25 **P Housing/PH1.25 xxP Housing 客户料号 Customer NO.
						X.X	±0.30			UNIT	mm	
						X.XX	±0.20			SIZE	A4	
						X.XXX	±0.10			SHEET	1/1	
AO	09/09/10		NEW			Angle	± 2'			PROJ.	客户料号 Customer NO.	
版次 REV	日期 DATE	变更说明 MODIFICATION DESCRIPTION	变更 CHANGE	核准 APPROVE	核准 APPROVE	DIM	TOL	核准 APPROVE				