

HSF

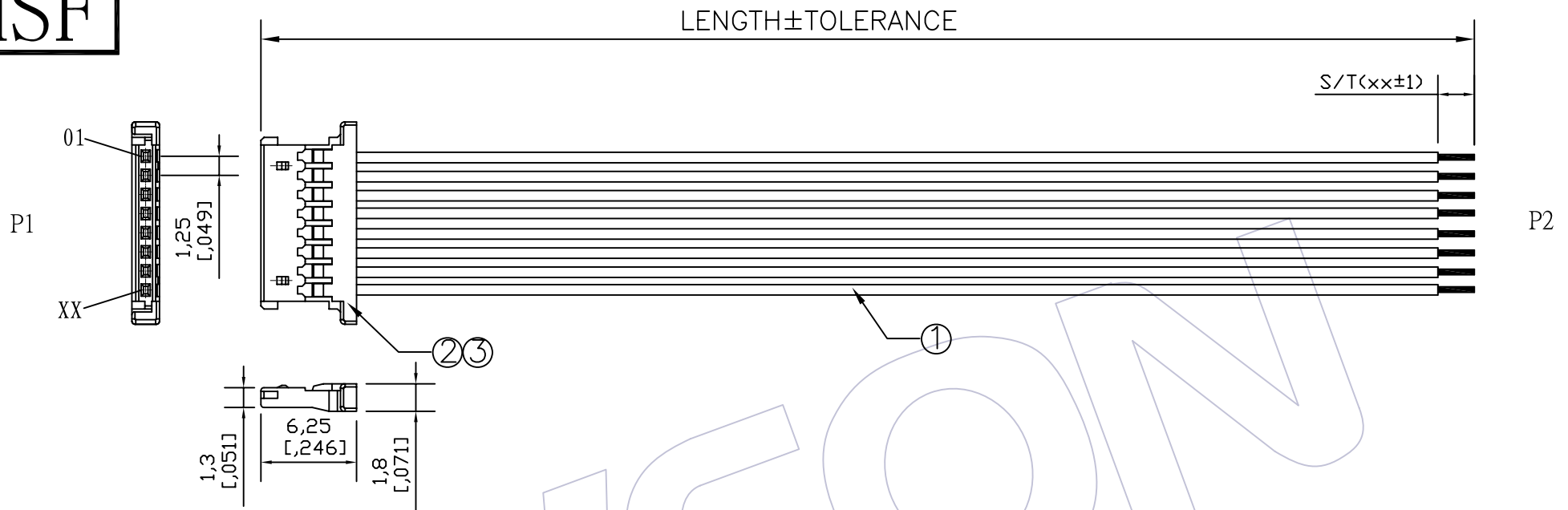

SPECIFICATIONS

Insulation Resistance: 5MΩ Min
 Contact Resistance: 3.0Ω Max
 Withstand Voltage: DC 300V, 10S
 The Cable Assembly Must 100% Test

CONNECT METHOD

P1	Color	P2
01	XXX	OPEN
02	XXX	OPEN
03	XXX	OPEN
XX	XXX	OPEN

Wire SPEC	LENGTH	TOLERANCE
ULxxxx 28~32AWG	1~499	±5
	500~999	±10
	1000~1500	±15
	1501~3000	±20
	3001~5000	±30
	5001~	± Lx1%

Ordering Information

C9110 - xx 01 xxx 301

No. of Pins: 02~30P
 Shape Style: 01=one end Process, another one end plate tin
 Length of Line

NO.	PART NO.	NAME	Specification	Q' TY	UNIT
③	WF1254-TPSN01	Terminal	PH1.25mm Phosphor Bronze Tin Terminal	xx	PCS
②	WF1254-HxxW01	Housing	PH1.25mm xxP White Housing	1	PCS
①	Wxxxx-1xxx00001	WIRE	UL: xxxx, AWG: 28-32, Color: xx, Wire	xxxx	MM

AO		09/09/18	NEW			工程图 ENGINEERING	绘图 DRAW	BEN	09/09/18	SCALE	FREE	WCON 维峰五金电子有限公司 WAVE HARDWARE ELECTRONICS CO. LTD	
版次 REV	日期 DATE	变更说明 MODIFICATION DESCRIPTION		变更 CHANGE	核准 APPROVE	X.X ±0.30	设计 DESIGN			UNIT	mm		
						X.XX ±0.20	审核 CHECK			SIZE	A4	品名 TITLE:	PH1.25 **P Housing TO OPEN
						X.XXX ±0.10	核准 APPROVE			SHEET	1/1	客户料号 Customer NO.	
						Angle ± 2'				PROJ.	客户料号 Customer NO.		
						DIM TOL							