

# HSF

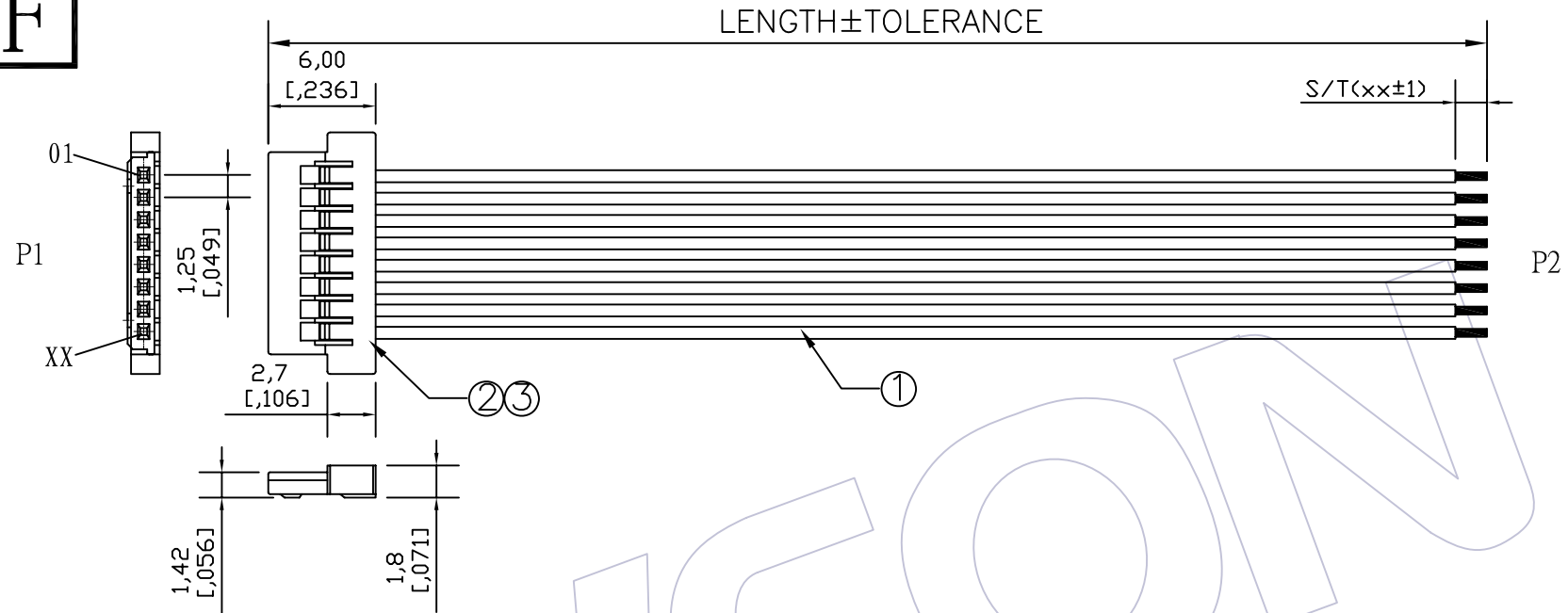

**SPECIFICATIONS**  
 Insulation Resistance: 5MΩ Min  
 Contact Resistance: 3.0Ω Max  
 Withstand Voltage: DC 300V, 10S  
 The Cable Assembly Must 100% Test

**CONNECT METHOD**

P1	Color	P2
01	XXX	OPEN
02	XXX	OPEN
03	XXX	OPEN
XX	XXX	OPEN

Wire SPEC	LENGTH	TOLERANCE
ULxxxx 28~32AWG	1~499	±5
	500~999	±10
	1000~1500	±15
	1501~3000	±20
	3001~5000	±30
	5001~	± Lx1%

### Ordering Information

C9110 - xx 01 xxx 101

No. of Pins: 02~16P      Shape Style: 01=one end Process, another one end plate tin      Length of Line

NO.	PART NO.	NAME	Specification	Q'TY	UNIT
③	WF1252-TPSN01	Terminal	PH1.25mm Phosphor Bronze Tin Terminal	xx	PCS
②	WF1252-Hxxx01	Housing	PH1.25mm xxP Color: xxx Housing	1	PCS
①	Wxxxx-1xxx00001	WIRE	UL: xxxx, AWG: 28-32, Color: xx, Wire	xxxx	MM

REV	DATE	MODIFICATION DESCRIPTION	CHANGE	APPROVE	SCALE	FREE	PROJ.	客户料号 Customer NO.
AO	09/09/18	NEW						
版次	日期	变更说明	变更	核准	工程图	绘图	BEN	09/09/18
REV	DATE	MODIFICATION DESCRIPTION	CHANGE	APPROVE	ENGINEERING	DRAW		
					X.X	±0.30		
					X.XX	±0.20		
					X.XXX	±0.10		
					Angle	± 2'		
					DIM	TOL		

**WCON** 维峰五金电子有限公司  
 WAVE HARDWARE ELECTRONICS CO. LTD

料号 PART NO. C9110-xx01xxx101  
 品名 TITLE: PH1.25 \*\*P Housing TO OPEN