

HSF

NOTES:

Rated Voltage:250V AC/DC
 Rated Current:2.0AMP
 Contact Resistance:20mΩ max
 Withstand Voltage:800V AC/Minute
 Insulation Resistance:1000MΩ min
 Operation Temperature: -25℃ to +85℃

Contact Material:Phosphor Bronze
 Contact plating:Sn over Ni or Au over Ni
 Fit wire Range:22#~28#AWG(O.D:1.50mm Max.)



Ordering Information

WF 2002 - T P SN 0 1

Material
 P=Phosphor bronze

Contact Plating
 S0=Gold Flash/Tin
 S3=10u"Gold/Tin
 S4=15u"Gold/Tin
 S5=30u"Gold/Tin
 SN=Tin

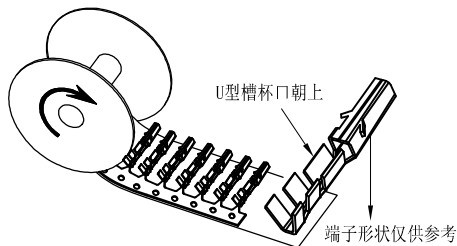

端子电镀后绕盘方向示意图

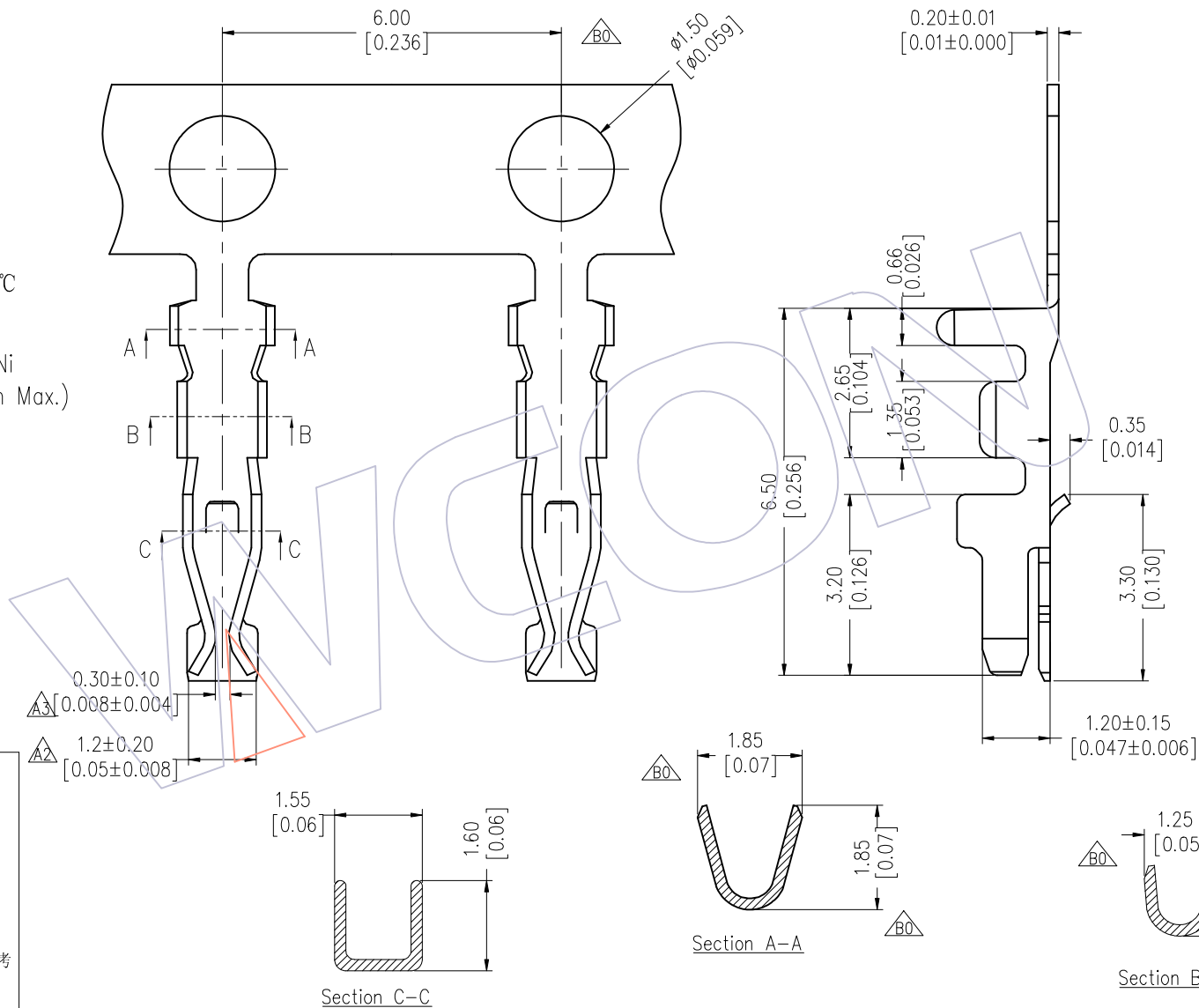

Section C-C

Section A-A

Section B-B

B0	22/06/23	增加绕盘方向示意图	—	OPERATION	DRAW	DATE	SCALE	FIT	PART NO.
A4	19/10/26	Modify drawing	—	X.X	LZH	22/06/23	UNIT	mm	SEE TAB
A3	17/09/18	Modify drawing	—	X.XX	CHECK	DATE	SIZE	A4	TITLE:
A0	08/07/30	NEW	—	X.XXX	APPROVE	DATE	SHEET	1/1	PHD2.00mm TERMINAL
REV	DATE	MODIFICATION DESCRIPTION	CHANGE	Angle			PROJ.	Customer NO.	
				DIM	TOL				

WCON

Http: www.wcon.com

WCON-Dongguan WCON-Kunshan
 Tel: +86 769 85358920 Tel: +86 512 57468408
 Fax: +86 769 85358915 Fax: +86 512 57468468
 E-mail: sales@wcon.com E-mail: wconks@wcon.com