

NOTES:

- Material:  
Housing: LCP, G.F, UL94V-0, BK  
Contact/strip: Copper Alloy
- Contact Plating:  
xxu"Gold on contact area(See Ordering Information)  
100u"Matte tin on solder area,  
50u" Nickel underplating overall.
- Ground strip: 100u"Matte tin over 50u" Nickel.
- Rated Current: 12.0A Max
- Contact Resistance: 10mΩ max
- Withstand Voltage: 2200V AC
- Insulation Resistance: 1000MΩ min
- Operation Temperature: -55°C to +105°C
- Soldering: Solder temperature: 260±5°C  
Solder time: 5±1S

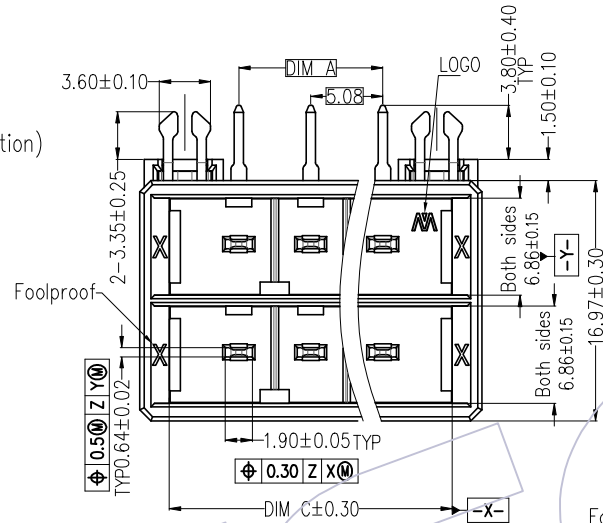

Pin	A	B	C	D
2*3	10.16	17.78	19.97	24.16
2*5	20.32	27.94	30.13	34.32
2*6	25.40	33.02	35.21	39.40

## Ordering Information

WD5085-2 WR XX XX B A XX W

2=Dual Row  
WR=90°DIP

No. of pins per row:  
03=3P  
05=5P  
06=6P

Contact Plated:  
SM=Matte Tin  
W1=3u"Gold/Matte Tin  
W4=15u"Gold/Matte Tin  
W5=30u"Gold/Matte Tin

W=W/T W Logo  
Blank=W/O W Logo

Foolproof  
04=XX Code  
05=YY Code  
06=XY Code  
07=YX Code  
08=ZX Code  
09=ZZ Code

A=Tray  
Housing Color  
B=Black

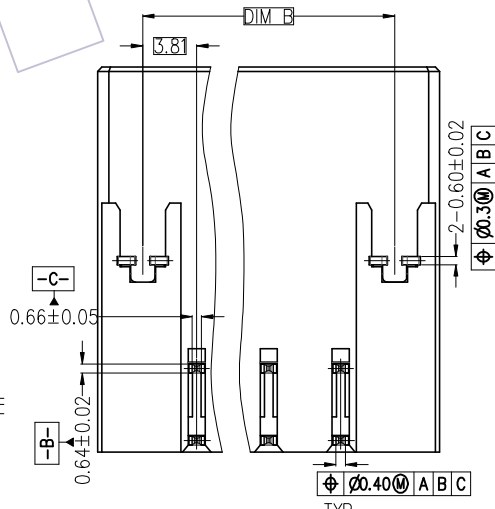
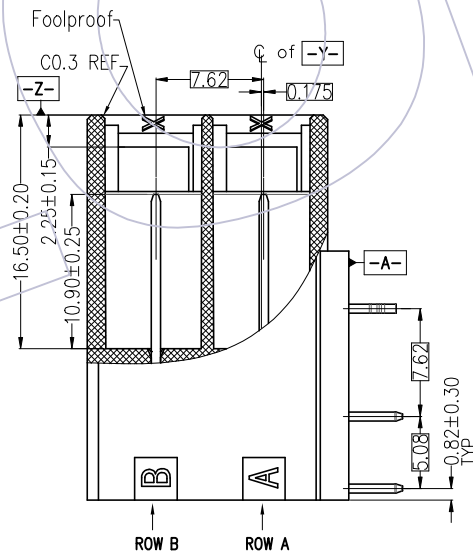
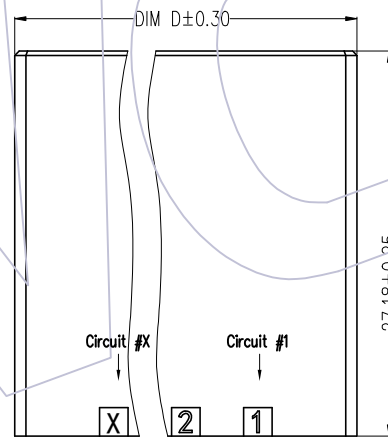

REV	DATE	MODIFICATION DESCRIPTION	CHANGE	OPERATION		DRAW	DATE	SCALE	FIT	PART NO.
				x.x	±0.40					
				x.xx	±0.25	CHECK	DATE			TITLE:
				x.xxx	±0.15	APPROVE	DATE			5.08*7.62mm Dyn. (T Type)
A0	2021/06/18	NEW	XSR	Angle	± 3'			SHEET	1/3	Dual Row 90°DIP with Ground strip
				DIM	TOL			PROJ.	Φ	Customer NO.

**WCON**  
Http: www.wcon.com

WCON-Dongguan  
Tel: +86 769 85358920  
Fax: +86 769 85358915  
E-mail: sales@wcon.com

WCON-Kunshan  
Tel: +86 512 57468408  
Fax: +86 512 57468468  
E-mail: salesks@wcon.com