

NOTES:
 Rated Current: 10.0 AMP
 Contact Resistance: 20 mΩ Max
 Withstand Voltage: 2000 V AC/DC
 Insulation Resistance: 1000 MΩ min
 Operation Temperature: -40°C to +105°C
 Wire Range: 26~12 AWG
 Wire Strip Length: 7 mm
 No. of Positions: 2~24
 Screw Counter Torsion Force: 3.5 lbf.in Min.

Terminal Material: Phosphor Bronze
 Terminal Plating:
 Matte Tin Plated Over Nickel
 Spring Blade Material: Stainless Steel
 Screw Material: Steel
 Screw Plating:

Nickel Plated Over All
 Up Cover Material:
 (High Temp.) Thermoplastic UL94 V-0
 Below Cover Material:
 (High Temp.) Thermoplastic UL94 V-0
 Push Pole Material:
 (High Temp.) Thermoplastic UL94 V-0

2P Without RAMP Locking "A"

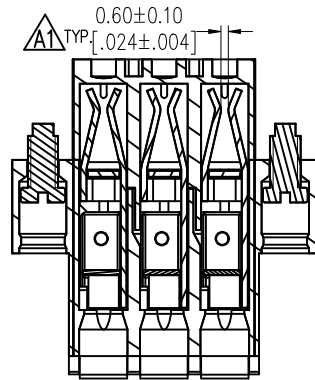

SEC A-A

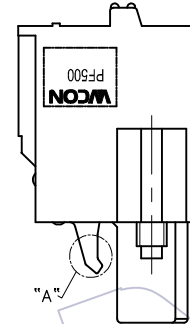
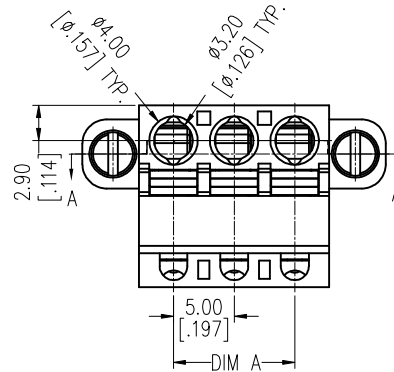

W/T WCON LOGO
 PF500S-1FXXASMW1

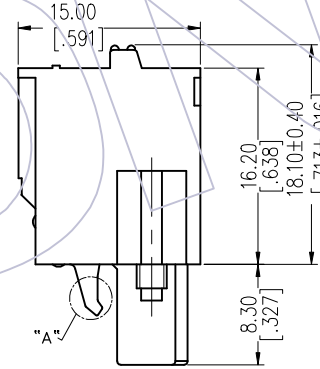
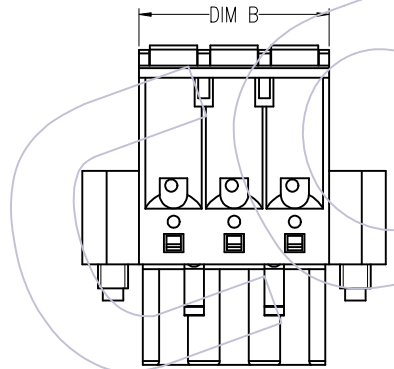
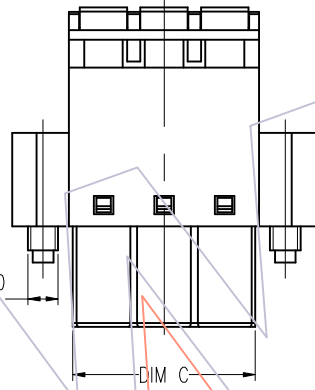
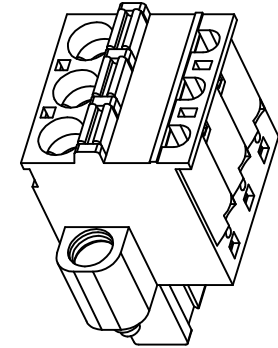

W/O WCON LOGO
 PF500S-1FXXASMW1N

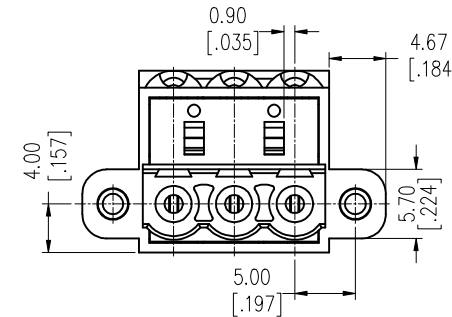

Ordering Information:

P F 500 S-1 F XX A SM W I N
 F=Female Pitch 500=5.00
 No. of Pins 02-24P
 Contact Plated Color A=Green
 SM=Matte Tin W=With Screw
 Type

Blank=W/T WCON LOGO
 N=W/O WCON LOGO

No. Of PIN	DIM.A	DIM.B	DIM.C
0 2	5.00±0.30	10.70±0.35	10.08±0.35
0 3	10.00±0.30	15.70±0.35	15.08±0.35
0 4	15.00±0.30	20.70±0.35	20.08±0.35
0 5	20.00±0.30	25.70±0.35	25.08±0.35
0 6	25.00±0.30	30.70±0.35	30.08±0.35
0 7	30.00±0.30	35.70±0.35	35.08±0.35
0 8	35.00±0.30	40.70±0.35	40.08±0.35
0 9	40.00±0.30	45.70±0.35	45.08±0.35
1 0	45.00±0.30	50.70±0.35	50.08±0.35
1 1	50.00±0.35	55.70±0.40	55.08±0.40
1 2	55.00±0.35	60.70±0.40	60.08±0.40
1 3	60.00±0.35	65.70±0.40	65.08±0.40
1 4	65.00±0.35	70.70±0.40	70.08±0.40
1 5	70.00±0.35	75.70±0.40	75.08±0.40
1 6	75.00±0.35	80.70±0.40	80.08±0.40
1 7	80.00±0.35	85.70±0.40	85.08±0.40
1 8	85.00±0.35	90.70±0.40	90.08±0.40
1 9	90.00±0.35	95.70±0.40	95.08±0.40
2 0	95.00±0.35	100.70±0.40	100.08±0.40
2 1	100.00±0.40	105.70±0.40	105.08±0.40
2 2	105.00±0.40	110.70±0.40	110.08±0.40
2 3	110.00±0.40	115.70±0.40	115.08±0.40
2 4	115.00±0.40	120.70±0.40	120.08±0.40

REV	DATE	MODIFICATION DESCRIPTION	CHANGE	OPERATION	DRAW	DATE	SCALE	FIT	PART NO.
A2	2019/06/20	Add W/T WCON LOGO	/	x.x ±0.40	XSR	2019/06/20	UNIT	mm	PF500S-1FXXASMW1(N)
A1	2019/05/19	Add Explosion view & Material List	/	x.xx ±0.25	CHECK	DATE	SIZE	A4	TITLE: 5.00mm Pitch Female Spring Plugs For Pluggable Terminal Blocks With Screw
A0	2019/03/19	NEW	/	x.xxx ±0.15	APPROVE	DATE	SHEET	1/2	Customer NO.
				Angle ± 3°			PROJ.		
				DIM TOL					

WCON

Http: www.wcon.com

WCON-Dongguan Tel: +86 769 85358920
 WCON-Kunshan Tel: +86 512 57468408
 Fax: +86 769 85358915
 Fax: +86 512 57468468
 E-mail: sales@wcon.com
 E-mail: salesks@wcon.com