

NOTES:
 Rated Current: 9.0AMP
 Contact Resistance: 30mΩ max
 Withstand Voltage: 1500V AC/minute
 Insulation Resistance: 1000MΩ min
 Operation Temperature: -25°C to +85°C

Contact Material: Brass
 Contact plating: Au Or Sn Over Ni
 Insulator Material: PA66(White Transparent
 UL94-V2 std)Or PA46(Natutal UL94-V0)

PART NO.	PIN	Dimension		Material
		A	B	
WF4201-2WSHXXX3	2*5P及以下	+0.30 -0.10	+0.40 -0.20	PA46
	2*5P以上	+0.50 -0.00	+0.60 -0.00	
WF4201-2WSXXX3	2*1P-2*12P	±0.20	±0.30	PA66

Recommended P.C.B Layout(Top Side)
 (PCB BOARD TOLERANCE±0.05)

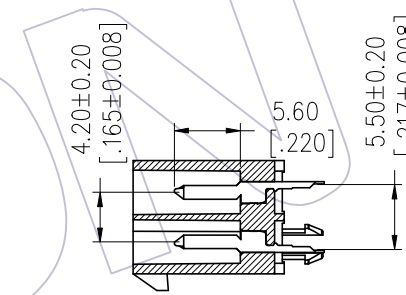
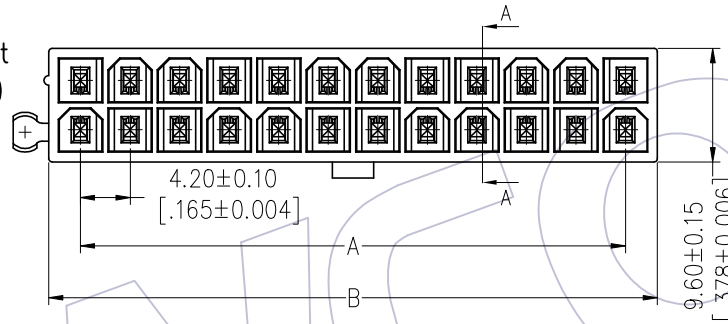
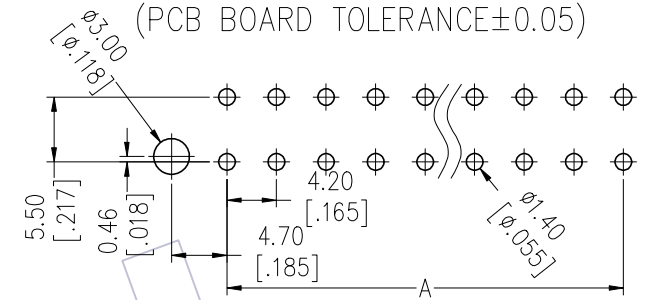

Ordering Information

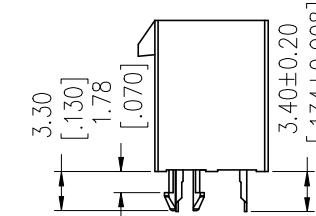
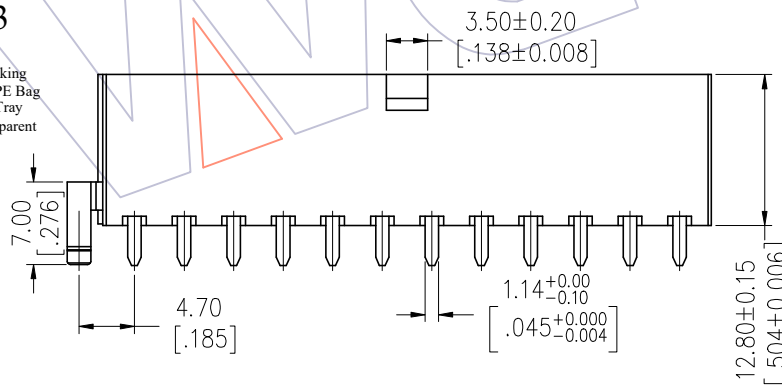
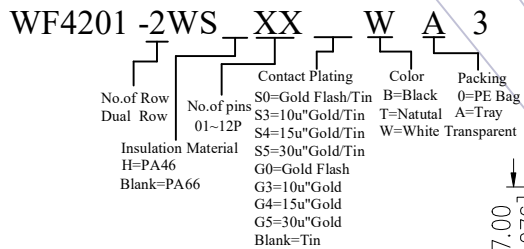

Specification & Ordering Information:

Circuit	Part No.	Dimension	
		A	B
2x01	WF4201-2WS01W03	---	5.40
2x02	WF4201-2WS02W03	4.20	9.60
2x03	WF4201-2WS03W03	8.40	13.80
2x04	WF4201-2WS04W03	12.60	18.00
2x05	WF4201-2WS05W03	16.80	22.20
2x06	WF4201-2WS06W03	21.00	26.40
2x07	WF4201-2WS07W03	25.20	30.60
2x08	WF4201-2WS08W03	29.40	34.80
2x09	WF4201-2WS09W03	33.60	39.00
2x10	WF4201-2WS10W03	37.80	43.20
2x11	WF4201-2WS11W03	42.00	47.40
2x12	WF4201-2WS12W03	46.20	51.60

REV	DATE	MODIFICATION DESCRIPTION	CHANGE	OPERATION		DRAW Ding	DATE	SCALE	FIT	PART NO.
				Angle	DIM					
A1	2019/05/15	Modify	---	X.X	±0.40	CHECK	2019/05/15	UNIT	mm	SEE TAB
AO	2012/09/17	NEW	---	X.XX	±0.25		DATE	SIZE	A4	
				X.XXX	±0.15		DATE	SHEET	1/2	
				Angle	± 3'	APPROVE	DATE	SHEET	1/2	TITLE: 4.20 MINI FIT DUAL ROW 180° WITH SHORT BUMP AND SINGLE POST
				DIM	TOL			PROJ.	Customer NO.	

WCON

Http: www.wcon.com

WCON-Dongguan Tel: +86 769 85358920 Fax: +86 769 85358915 E-mail: sales@wcon.com

WCON-Kunshan Tel: +86 512 57468408 Fax: +86 512 57468468 E-mail: salesks@wcon.com