

NOTES:  
 Rated Current: See Table A  
 Contact Resistance: 30mΩ max  
 Withstand Voltage: 1500V AC/minute  
 Insulation Resistance: 1000MΩ min  
 Operation Temperature: -25°C to +85°C

Contact Material: Brass  
 Contact Plating: Au Or Sn Over Ni  
 Insulator Material: PA66(White Transparent UL94-V2 std)  
 Or PA46(Natutal UL94-V0)

PART NO.	PIN	A	B	Material
WF4201-2WSHXXX1	2*5P及以下	+0.30 -0.10	+0.40 -0.20	PA46
	2*5P以上	+0.50 -0.00	+0.60 -0.00	
WF4201-2WSXXX1	2*1P-2*12P	±0.20	±0.30	PA66

Recommended P.C.B Layout(Top Side)  
 (PCB BOARD TOLERANCE±0.05)

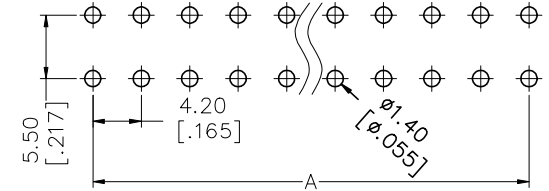

Size Wire	Ckt	2&3	4-6	7-10	12-24
AWG#18	9A	8A	7A	6A	6A
AWG#20	7A	6A	5A	5A	5A
AWG#22	5A	4A	4A	4A	4A
AWG#24	4A	3A	3A	3A	3A

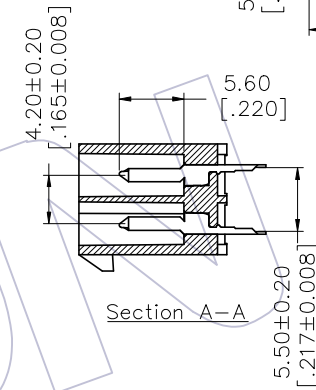
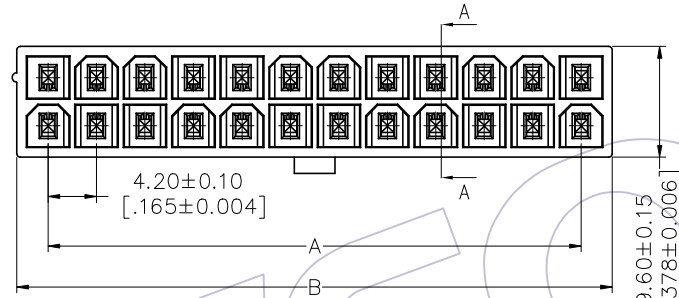

## Ordering Information

WF4201 -2WS XX W A 1

No. of Row Dual Row  
 No. of pins 01-12P  
 Contact Plating  
 S0=Gold Flash/Tin  
 S3=10u"Gold/Tin  
 S4=15u"Gold/Tin  
 S5=30u"Gold/Tin  
 G0=Gold Flash  
 G3=10u"Gold  
 G4=15u"Gold  
 G5=30u"Gold  
 Blank=Tin  
 Insulation Material  
 H=PA46  
 Blank=PA66  
 Color  
 B=Black  
 T=Natutal  
 W=White Transparent  
 Packing  
 0=PE Bag  
 A=Tray

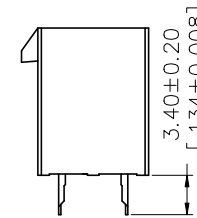
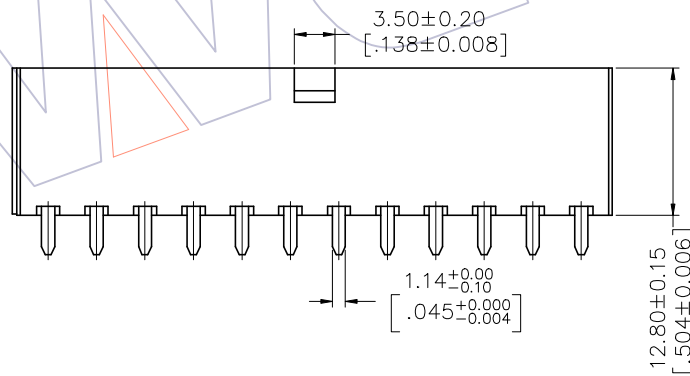

## Dimensional & Ordering Information

Circuit	Part No.	Dimension	
		A	B
2x01	WF4201-2WS01X01	---	5.40
2x02	WF4201-2WS02X01	4.20	9.60
2x03	WF4201-2WS03X01	8.40	13.80
2x04	WF4201-2WS04X01	12.60	18.00
2x05	WF4201-2WS05X01	16.80	22.20
2x06	WF4201-2WS06X01	21.00	26.40
2x07	WF4201-2WS07X01	25.20	30.60
2x08	WF4201-2WS08X01	29.40	34.80
2x09	WF4201-2WS09X01	33.60	39.00
2x10	WF4201-2WS10X01	37.80	43.20
2x11	WF4201-2WS11X01	42.00	47.40
2x12	WF4201-2WS12X01	46.20	51.60

REV	DATE	MODIFICATION DESCRIPTION	CHANGE	OPERATION	DRAW	DATE	SCALE	FIT	PART NO.
A2	2023/07/08	Modify Rated Current: See Table A	DuYing	X.X ±0.40	Ding	2023/07/08	UNIT mm		SEE TAB
A1	2019/05/15	Modify	---	X.XX ±0.25	CHECK	DATE	SIZE A4		TITLE: 4.20 MINI FIT DUAL ROW 180° WITH SHORT BUMP WITHOUT POST
AO	2012/09/17	NEW	---	X.XXX ±0.15	APPROVE	DATE	SHEET 1/2		Customer NO.
				Angle ± 3°			PROJ.		
				DIM TOL					

**WCON**

Http: www.wcon.com

WCON-Dongguan  
 Tel: +86 769 85358920  
 Fax: +86 769 85358915  
 E-mail: sales@wcon.com

WCON-Kunshan  
 Tel: +86 512 57468408  
 Fax: +86 512 57468468  
 E-mail: salesks@wcon.com