

HSF

NOTES:

Rated Current: 3.0AMP
 Contact Resistance: 20mΩ max
 Withstand Voltage: 1000V AC
 Insulation Resistance: 1000MΩ min
 Operation Temperature: -25°C to +85°C

Contact Material: Brass
 Contact plating: Au Or Sn Over Ni
 Insulator Material: PA66 Or PA46 UL94V-0

Recommended P.C.B Layout(Top Side)
 (PCB BOARD TOLERANCE ±0.05)

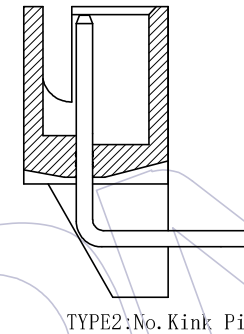
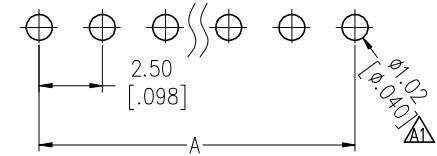
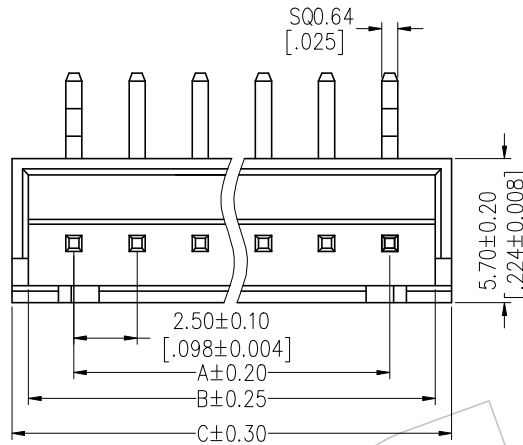

TITLE	PART NO.
TYPE 1	WF2501-WRXXX01
TYPE 2	WF2501-WRXXX02

Ordering Information

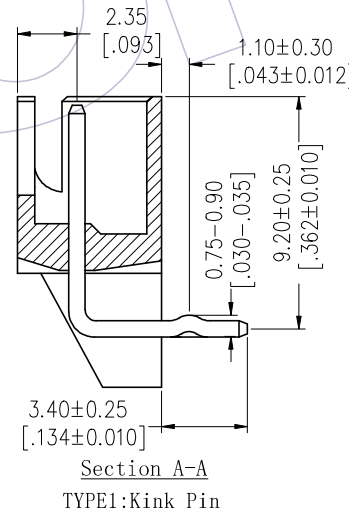
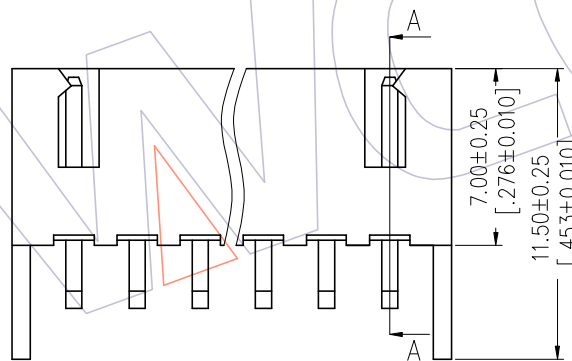
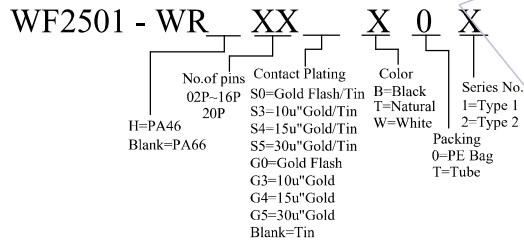

Specification & Ordering Information:

Circuit	Part No.	Dimension		
		A	B	C
02	WF2501-WR02X0X	2.50	6.1	7.4
03	WF2501-WR03X0X	5.00	8.6	9.9
04	WF2501-WR04X0X	7.50	11.1	12.4
05	WF2501-WR05X0X	10.00	13.6	14.9
06	WF2501-WR06X0X	12.50	16.1	17.4
07	WF2501-WR07X0X	15.00	18.6	19.9
08	WF2501-WR08X0X	17.50	21.1	22.4
09	WF2501-WR09X0X	20.00	23.6	24.9
10	WF2501-WR10X0X	22.50	26.1	27.4
11	WF2501-WR11X0X	25.00	28.6	29.9
12	WF2501-WR12X0X	27.50	31.1	32.4
13	WF2501-WR13X0X	30.00	33.6	34.9
14	WF2501-WR14X0X	32.50	36.1	37.4
15	WF2501-WR15X0X	35.00	38.6	39.9
16	WF2501-WR16X0X	37.50	41.1	42.4
20	WF2501-WR20X0X	47.50	51.1	52.4

REV	DATE	MODIFICATION DESCRIPTION	CHANGE	OPERATION	DRAW	DATE	SCALE	FIT	PART NO.
A1	2013/10/24	Modify The PCB Hole Dim	—	X.X ±0.40	JYHuang	2013/10/24	UNIT	mm	SEE TAB
A0	2012/09/05	NEW	—	X.XX ±0.25	CHECK	DATE	SIZE	A4	TITLE:
				X.XXX ±0.15	APPROVE	DATE	SHEET	1/1	"J"TYPE 2.50 WAFER 90° DIP
				Angle ± 3°			PROJ.		Customer NO.
				DIM TOL					

WCON
 Http: www.wcon.com

WCON-Dongguan WCON-Kunshan
 Tel: +86 769 85358920 Tel: +86 512 57468408
 Fax: +86 769 85358915 Fax: +86 512 57468468
 E-mail: sales@wcon.com E-mail: salesks@wcon.com